

PERFORMANCE
MADE
SMARTER

Product Manual

9203

Solenoid / alarm driver

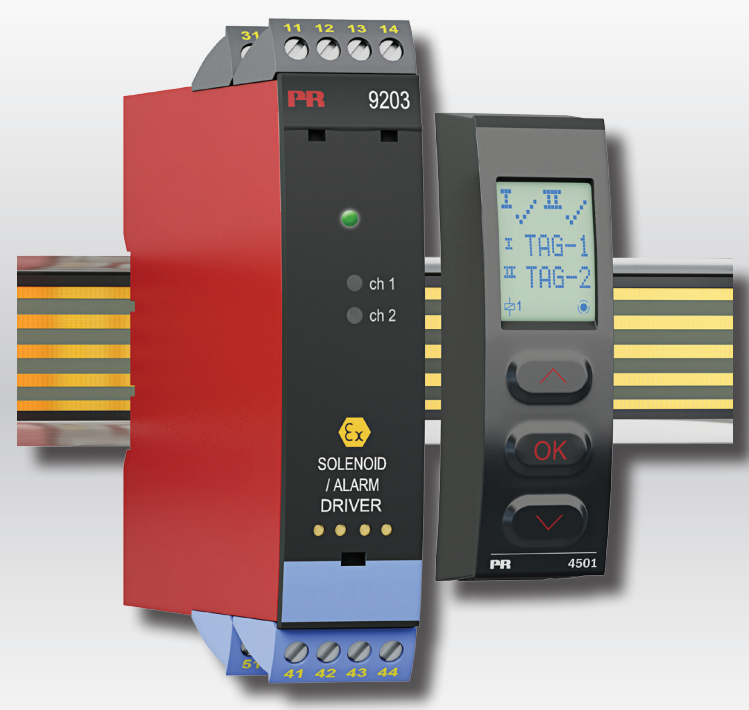

TEMPERATURE | I.S. INTERFACES | COMMUNICATION INTERFACES | MULTIFUNCTIONAL | ISOLATION | DISPLAY

No. 9203V107-UK
Product version: 9203-003



6 Product Pillars

to meet your every need

Individually outstanding, unrivalled in combination

With our innovative, patented technologies, we make signal conditioning smarter and simpler. Our portfolio is composed of six product areas, where we offer a wide range of analog and digital devices covering over a thousand applications in industrial and factory automation. All our products comply with or surpass the highest industry standards, ensuring reliability in even the harshest of environments and have a 5-year warranty for greater peace of mind.



Temperature

Our range of temperature transmitters and sensors provides the highest level of signal integrity from the measurement point to your control system. You can convert industrial process temperature signals to analog, bus or digital communications using a highly reliable point-to-point solution with a fast response time, automatic self-calibration, sensor error detection, low drift, and top EMC performance in any environment.



I.S. Interface

We deliver the safest signals by validating our products against the toughest safety standards. Through our commitment to innovation, we have made pioneering achievements in developing I.S. interfaces with SIL 2 Full Assessment that are both efficient and cost-effective. Our comprehensive range of analog and digital intrinsically safe isolation barriers offers multifunctional inputs and outputs, making PR an easy-to-implement site standard. Our backplanes further simplify large installations and provide seamless integration to standard DCS systems.



Communication

We provide inexpensive, easy-to-use, future-ready communication interfaces that can access your PR installed base of products. The detachable 4501 Local Operator Interface (LOI) allows for local monitoring of process values, device configuration, error detection and signal simulation. The next generation, our 4511 Remote Operator Interface (ROI) does all that and more, adding remote digital communications via Modbus/RTU, while the analog output signals are still available for redundancy.

With the 4511 you can further expand connectivity with a PR gateway, which connects via industrial Ethernet, wirelessly through a Wi-Fi router or directly with the devices using our Portable Plant Supervisor (PPS) application. The PPS app is available for iOS, Android and Windows.



Multifunction

Our unique range of single devices covering multiple applications is easily deployable as your site standard. Having one variant that applies to a broad range of applications can reduce your installation time and training, and greatly simplify spare parts management at your facilities. Our devices are designed for long-term signal accuracy, low power consumption, immunity to electrical noise and simple programming.



Isolation

Our compact, fast, high-quality 6 mm isolators are based on microprocessor technology to provide exceptional performance and EMC-immunity for dedicated applications at a very low total cost of ownership. They can be stacked both vertically and horizontally with no air gap separation between units required.



Display

Our display range is characterized by its flexibility and stability. The devices meet nearly every demand for display readout of process signals, and have universal input and power supply capabilities. They provide a real-time measurement of your process value no matter the industry, and are engineered to provide a user-friendly and reliable relay of information, even in demanding environments.

Solenoid / alarm driver

9203

Table of contents

Warning	4
Symbol identification	4
Safety instructions	4
How to demount system 9000	5
Advanced features	6
Application	6
Technical characteristics	6
Applications - 9203Axxx	7
Applications - 9203Bxxx	8
PR 4511/4501 display / programming front	9
Mounting / demounting the PR 4511/4501	9
Order	10
Input type selector	10
Accessories	10
Technical data	10
Output loads	12
Visualisation in 4511/4501 of hardware / software error	15
Connections	16
Block diagram	17
Signal error indications without display front	18
Configuration / operating the function keys	19
Routing diagram	20
Routing diagram, advanced settings (ADV.SET)	21
Help text overview	22
Appendix	23
IECEX Installation Drawing	24
ATEX Installation Drawing	28
FM Installation Drawing	32
Desenho de instalação INMETRO	35
Document history	38
Safety Manual	39

Warning



The following operations should only be carried out on a disconnected device and under ESD-safe conditions:

- General mounting, wire connection and disconnection.
- Troubleshooting the device.

Repair of the device and replacement of circuit breakers must be done by PR electronics A/S only.

Warning



Do not open the front plate of the device as this will cause damage to the connector for the display / programming front PR 4511/4501.

This device contains no DIP-switches or jumpers.

Symbol identification



Triangle with an exclamation mark: Read the manual before installation and commissioning of the device in order to avoid incidents that could lead to personal injury or mechanical damage. arning/ demand. Potentially lethal situations.



The CE mark proves the compliance of the device with the essential requirements of the directives.



The double insulation symbol shows that the device is protected by double or reinforced insulation.



Ex devices have been approved acc. to the ATEX directive for use in connection with installations in explosive areas. See installation drawings in appendix.

Safety instructions

Definitions

Hazardous voltages have been defined as the ranges: 75 to 1500 Volt DC, and 50 to 1000 Volt AC.

Technicians are qualified persons educated or trained to mount, operate, and also trouble-shoot technically correct and in accordance with safety regulations.

Operators, being familiar with the contents of this manual, adjust and operate the knobs or potentiometers during normal operation.

Receipt and unpacking

Unpack the device without damaging it and check whether the device type corresponds to the one ordered. The packing should always follow the device until this has been permanently mounted.

Environment

Avoid direct sun light, dust, high temperatures, mechanical vibrations and shock, and rain and heavy moisture. If necessary, heating in excess of the stated limits for ambient temperatures should be avoided by way of ventilation.

The device must be installed in pollution degree 2 or better.

The device is designed to be safe at least under an altitude up to 2 000 m.

Mounting

Only technicians, who are familiar with the technical terms, warnings, and instructions in the manual and who are able to follow these, should connect the device. Should there be any doubt as to the correct handling of the device, please contact your local distributor or, alternatively,

PR electronics A/S
www.prelectronics.com

The use of stranded wires is not permitted for mains wiring except when wires are fitted with cable ends.

Descriptions of input / output and supply connections are shown in the block diagram and on the side label.

The device is provided with field wiring terminals and shall be supplied from a Power Supply having double / reinforced insulation. A power switch shall be easily accessible and close to the device. The power switch shall be marked as the disconnecting unit for the device.

For installation on Power Rail 9400 the power is supplied by Power Control Unit 9410.

Year of manufacture can be taken from the first two digits in the serial number.

Calibration and Adjustment

During calibration and adjustment, the measuring and connection of external voltages must be carried out according to the specifications of this manual. The technician must use tools and instruments that are safe to use.

Normal operation

Operators are only allowed to adjust and operate devices that are safely fixed in panels, etc., thus avoiding the danger of personal injury and damage. This means there is no electrical shock hazard, and the device is easily accessible.

Cleaning

When disconnected, the device may be cleaned with a cloth moistened with distilled water.

Liability

To the extent the instructions in this manual are not strictly observed, the customer cannot advance a demand against PR electronics A/S that would otherwise exist according to the concluded sales agreement.

How to demount system 9000

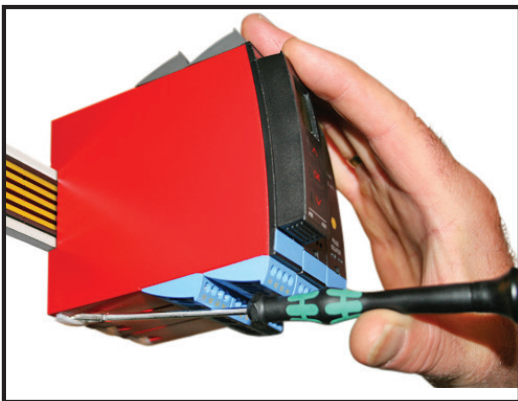

Picture 1:

By lifting the bottom lock, the device is detached from the DIN rail.

Solenoid / alarm driver 9203

- Universal driver for solenoids, acoustic alarms and LEDs
- Extended self-diagnostics
- 1 or 2 channels
- Can be supplied separately or installed on power rail, PR 9400
- SIL 2-certified via Full Assessment

Advanced features

- The 9203Bxxx features three built-in Ex barriers.
- Two hardware versions make it possible to choose either Low (35 mA) or High (60 mA) current output.
- Configuration and monitoring by way of detachable display front (PR 4511/4501).
- Selection of direct or inverted function for each channel via PR 4511/4501 and the possibility of reducing the output current to the hazardous area to suit the application.
- Optional monitoring of the output current to the hazardous area by way of PR 4511/4501.
- Optional redundant supply via power rail and/or separate supply.

Application

- The 9203Bxxx can be mounted in the safe area or in zone 2 / div. 2 and transmit signals to zone 0, 1, 2 and zone 20, 21, 22 including M1 mining / Class I/II/III, Div. 1, Gr. A-G. Ex driver for the control of ON / OFF solenoids, acoustic alarms and LEDs mounted in the hazardous area.
- The 9203Axxx can be mounted in the safe area or zone 2 / div. 2 and transmit signals to non-hazardous area. Driver for the control of ON / OFF solenoids, acoustic alarms and LEDs mounted in safe area.
- Monitoring of internal error events via the individual status relay and/or a collective electronic signal via the power rail.
- The 9203 has been designed, developed and certified for use in SIL 2 applications according to the requirements of IEC 61508.

Technical characteristics

- 1 green and 2 yellow/red front LEDs indicate operation status and malfunction.
- 2.6 kVAC galvanic isolation between input, output and supply.

Applications - 9203Axxx

Output signals:

Input signals:

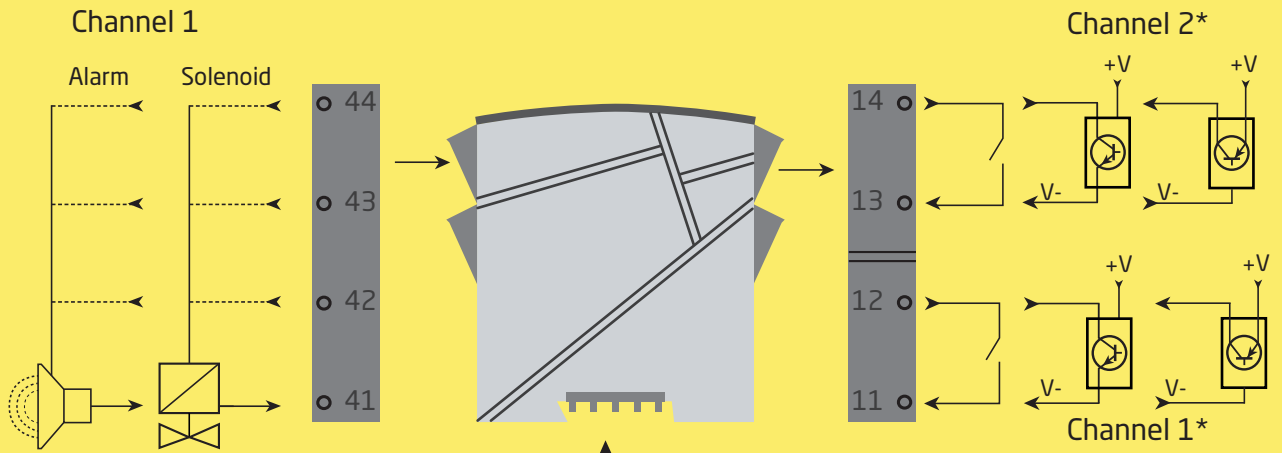

* For full overview of input connections, refer to page 16.

Power rail

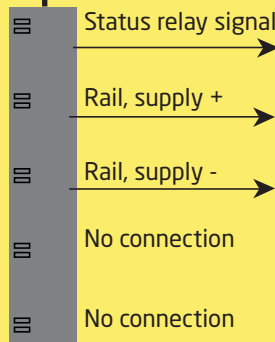

Channel 2

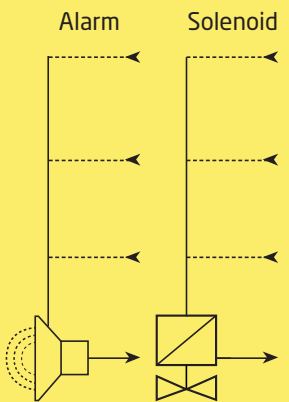

Power connection:

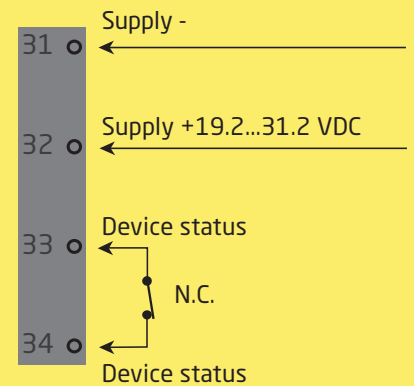

Supply via power rail

Zone 2 / Cl. 1, div. 2, gr. A-D or safe area



Applications - 9203Bxxx

Output signals:

Channel 1

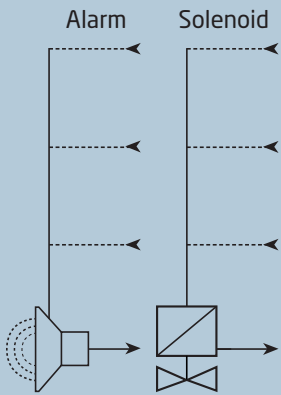

Channel 2

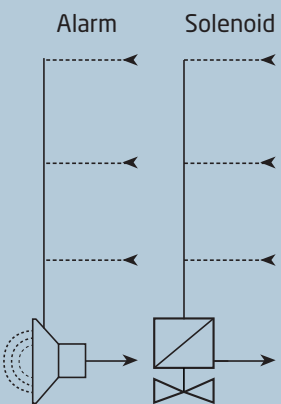

Input signals:

Channel 2*

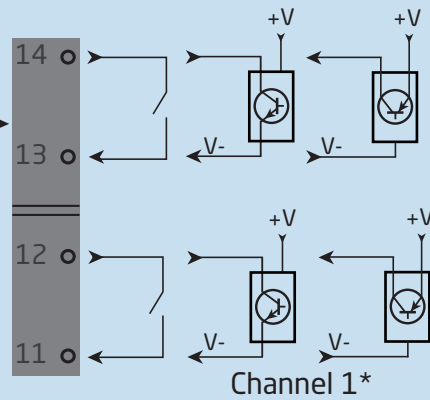

* For full overview of input connections, refer to page 16.

Power rail

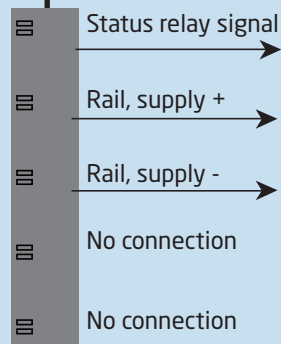

Power connection:

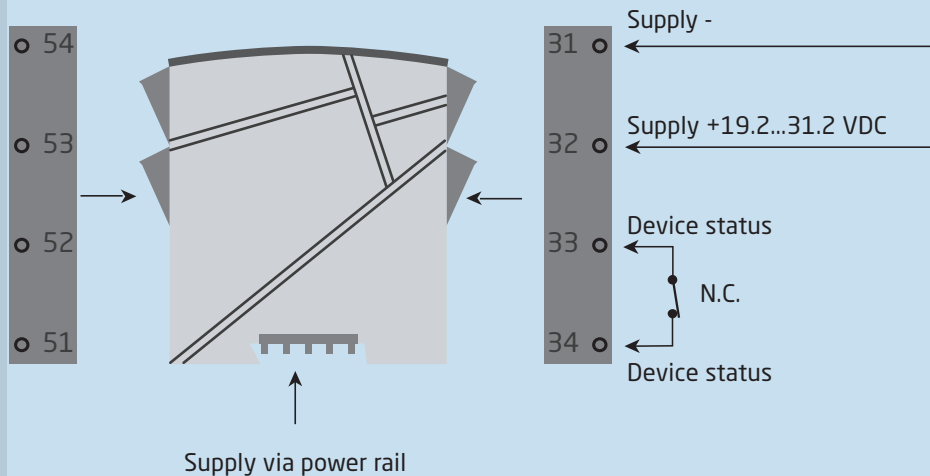

**Zone 0, 1, 2,
20, 21, 22, M1 &
Cl. I/II/III, Div. 1
gr. A-G**

**Zone 2 & Cl. 1, Div. 2, gr. A-D
or Safe Area**

PR 4511/4501 display / programming front



Functionality

The simple and easily understandable menu structure and the explanatory help texts guide you effortlessly and automatically through the configuration steps, thus making the product very easy to use. Functions and configuration options are described in the section "Configuration / operating the function keys".

Application

- Communications interface for modification of operational parameters in 9203.
- When mounted in the process, the display shows process values and device status.

Technical characteristics

- LCD display with 4 lines:
 - Line 1 (H=5.57 mm) shows status for each channel (OK or error).
 - Line 2 (H=3.33 mm) shows output for channel 1 (ON / OFF).
 - Line 3 (H=3.33 mm) shows output for channel 2 (ON / OFF).
 - Line 4 shows whether the device is SIL-locked. Static dot = SIL-locked and flashing dot = not SIL-locked.
 - Line 4 also indicates if the output is active.
- In order to protect the configuration against unauthorised changes, access to the menus can be blocked by a password.

Mounting / demounting the PR 4511/4501

- 1: Insert the tabs of the PR 4511/4501 into the holes at the top of the device.
- 2: Hinge the PR 4511/4501 down until it snaps into place.

Demounting of the PR 4511/4501

- 3: Push the release button on the bottom of the PR 4511/4501 and hinge the the PR 4511/4501 out and up.
- 4: With the PR 4511/4501 hinged up, remove from holes at the top of the device.

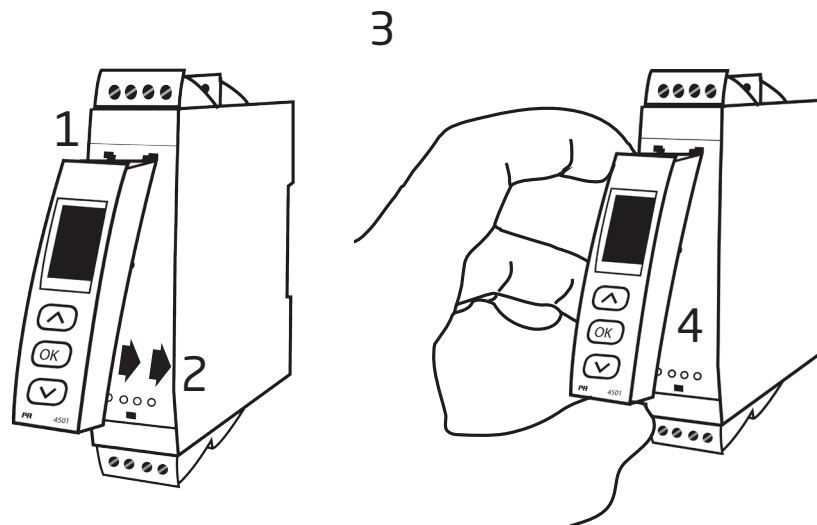

Order

Type	Version	Output	Channels	Input
9203	Non-Ex / zone 2 : A	Low current : 1	Single : A	Opto / switch :-
	Ex barrier [Ex ia] / zone 2 : B		Double : B	PNP : 1
		High current : 2	Single : A	NPN : 2

Example: 9203B2B2

Input type selector

	9203xxx	9203xxx1	9203xxx2
NPN open collector	x		x
PNP open collector	x	x	
Switch	x	x	x
Active signal		x	x

Accessories

- 4501 = Display / programming front
- 4511 = Communication enabler
- 9400 = Power rail
- 9404 = Module stop for rail
- 9410 = Power control unit
- 9421 = Power supply 24 V - Ex nA nC

Technical data

Environmental conditions:

- Specifications range. -20°C to +60°C
- Storage temperature -20°C to +85°C
- Calibration temperature. 20...28°C
- Relative humidity < 95% RH (non-cond.)
- Protection degree IP20
- Installation in. Pollution degree 2 & overvoltage category II.

Mechanical specifications:

- Dimensions (HxWxD) 109 x 23.5 x 104 mm
- Dimensions (HxWxD) w/ 4501 / 4511 109 x 23.5 x 116 / 131 mm
- Weight approx. 170 g
- Weight incl. 4501 / 4511 (approx.) 185 g / 270 g
- DIN rail type. DIN EN 60715 - 35 mm
- Wire size. 0.13...2.08 mm² / AWG 26...14 stranded wire
- Screw terminal torque. 0.5 Nm
- Vibration. IEC 60068-2-6 : 2007
- 2...13.2 Hz ±1 mm
- 13.2...100 Hz. ±0.7 g

Common electrical specifications:

- Supply voltage 19.2...31.2 VDC
- Fuse 1.25 A SB / 250 VAC

Type	Description	Max. power dissipation	Max. required power
9203x1A	1 ch., low current	≤ 1.1 W	≤ 1.9 W
9203x1A1	1 ch., low current	≤ 1.1 W	≤ 1.9 W
9203x1A2	1 ch., low current	≤ 1.1 W	≤ 1.9 W
9203x1B	2 ch., low current	≤ 2.0 W	≤ 3.1 W
9203x1B1	2 ch., low current	≤ 2.0 W	≤ 3.1 W
9203x1B2	2 ch., low current	≤ 2.0 W	≤ 3.1 W
9203x2A	1 ch., high current	≤ 1.7 W	≤ 2.5 W
9203x2A1	1 ch., high current	≤ 1.7 W	≤ 2.5 W
9203x2A2	1 ch., high current	≤ 1.7 W	≤ 2.5 W

Max. required power is the maximum power needed at terminals 31 and 32.

Max. power dissipation is the maximum power dissipated by the device.

If the 9203 is used with the 4511 / 4501, then add 40 mW to the max. power dissipation and 70 mW to the max. required power for each device with the 4511 / 4501.

Isolation - test / working:

Input / output / supply 2.6 kVAC / 250 VAC reinforced isolation
Output 1 to output 2 1.5 kVAC / 150 VAC reinforced isolation
Status relay to supply 1.5 kVAC / 150 VAC reinforced isolation
Communications interface Communication enabler 4511 /
Programming front 4501

EMC - immunity influence.	< ±0.5% of span
Extended EMC immunity:	
NAMUR NE 21, A criterion, burst	< ±1% of span

9203xxx NPN open collector and mechanical switch:

Trig level LOW ≤ 2.0 VDC
Trig level HIGH ≥ 4.0 VDC
Max. external voltage 28 VDC
Input impedance 3.5 kΩ
V open input 6.0 VDC

9203xxx PNP open collector:

Trig level LOW ≤ 8.0 VDC
Trig level HIGH ≥ 10.0 VDC
Max. external voltage 28 VDC
Input impedance 3.5 kΩ
V open input 6.0 VDC

9203xxx1 PNP with pull-down resistor:

Trig level low ≤ 8.0 VDC
Trig level high ≥ 10.0 VDC
Max external voltage 28 VDC
Input impedance 3.5 kΩ
V open input 6.5 VDC

9203xxx2 NPN with pull-up resistor:

Trig level low ≤ 2.0 VDC
Trig level high ≥ 4.0 VDC
Max external voltage 28 VDC
Input impedance 3.5 kΩ
V open input 6.0 VDC

Outputs:

Output ripple < 40 mV RMS

Output loads

Terminal	9203x1Ax (1 channel) / 9203x1Bx (2 channels)		
	41-42 / 51-52	41-43 / 51-53	41-44 / 51-54
Vout. no load	Min. 24 V	Min. 24 V	Min. 24 V
Vout. with load	Min. 12.5 V	Min. 13.5 V	Min. 14.5 V
Iout. max	35 mA	35 mA	35 mA

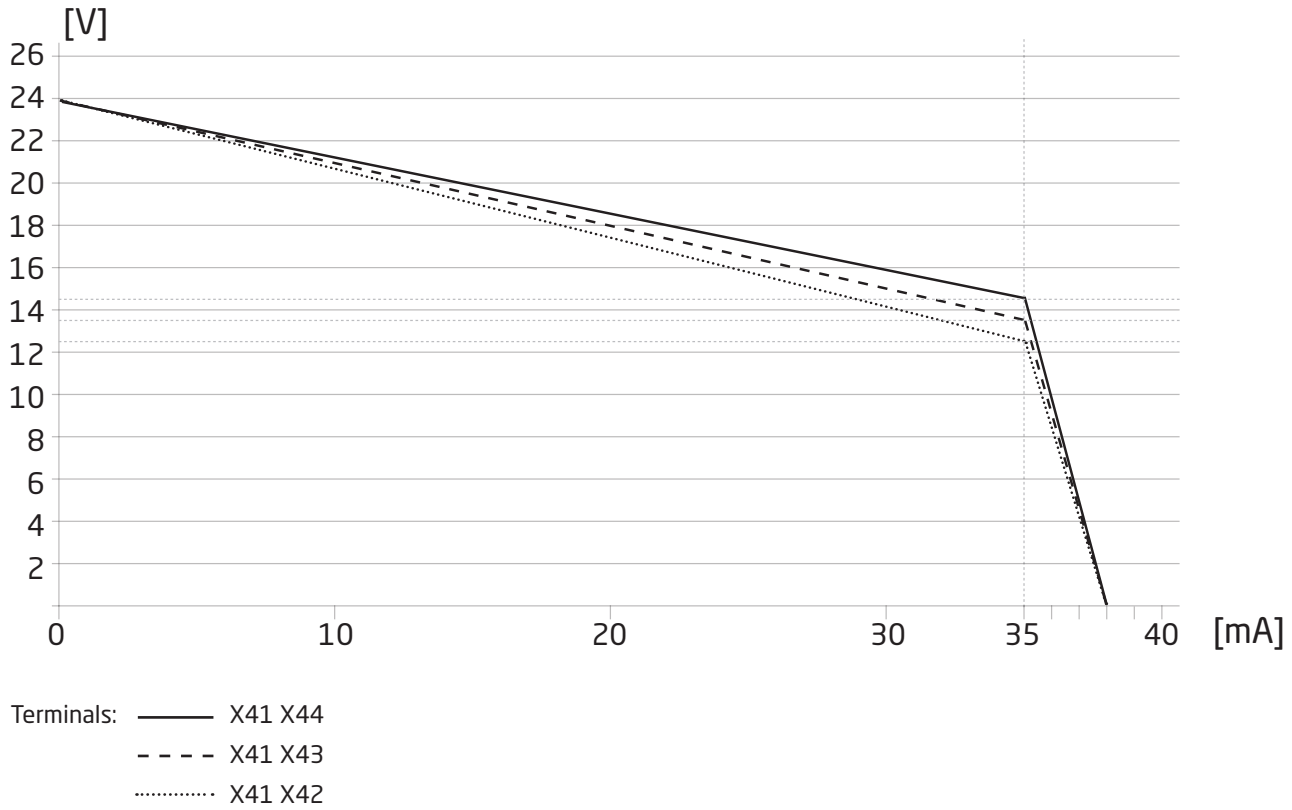

Terminal	9203x2Ax (1 channel)					
	41-42		41-43		41-44	
Vout. no load	Min. 24 V		Min. 24 V		Min. 24 V	
Vout. with load	Min. 11.5 V	Min. 9 V	Min. 12.5 V	Min. 10 V	Min. 13.5 V	Min. 11 V
Iout. max	50 mA	60 mA	50 mA	60 mA	50 mA	60 mA

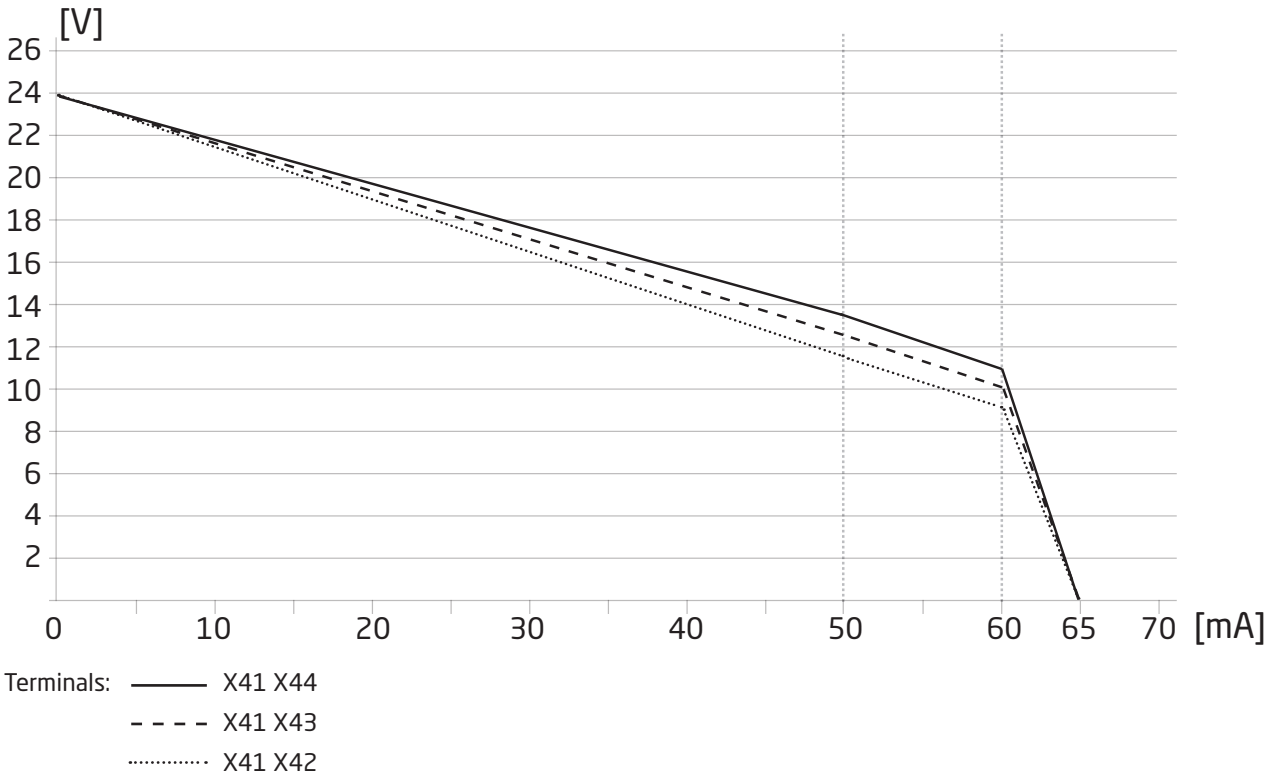

Relay output:

Status relay in safe area:

Max. voltage	125 VAC / 110 VDC
Max. current	0.5 A AC / 0.3 A DC
Max. power	62.5 VA / 32 W

Observed authority requirements:

EMC	2014/30/EU
LVD	2014/35/EU
RoHS	2011/65/EU

Approvals:

DNV-GL, Ships & Offshore	Standard for Certification No. 2.4
c UL us, Standard for Safety	UL 61010-1
EAC	TR-CU 020/2011

I.S. / Ex:

ATEX 2014/34/EU	KEMA 07ATEX0147 X
IECEX	IECEX KEM 09.0001X
c FM us.	3035277-C
INMETRO	DEKRA 16.0006 X
CCOE	P337349/6
EAC Ex TR-CU 012/2011	RU C-DK.GB08.V.00410

Functional Safety:

SIL2 Certified & Fully Assessed acc. to IEC 61508

Visualisation in 4511/4501 of hardware / software error

Readout at hardware error		
Error search	Readout	Cause
Communications test 4511 (4501) / 9203	NO.CO	Connection error
EEprom error - check configuration	FL.ER	Configuration error or crc mismatch, recovery configuration is loaded
Hardware error	DE.ER	Invalid recovery configuration in device
Hardware error	FC.ER	Invalid code checksum in 4511/4501
EEprom error - check configuration	CO.ER	Invalid configuration (CRC or data)
Hardware error	CA.ER	Factory calibration error
Hardware error	HW.ER	HW setup - configuration mismatch
Hardware error	OC.ER	Main output controller communication error
Hardware error	MS.ER	Main internal supply out of bounds
Hardware error	MI.ER	Main initialisation selftest failed
Hardware error	MC.ER	Main flash or ram selftest failed

! All error indications in the display flash once per second. The help text explains the error.
Errors affecting both channels are shown as error on channel 1 - and the line showing channel 2 is blank.
Hardware error can be reset in two ways. Either step through the menus (if the other channel is to stay in operation) or power cycle the device.

Connections

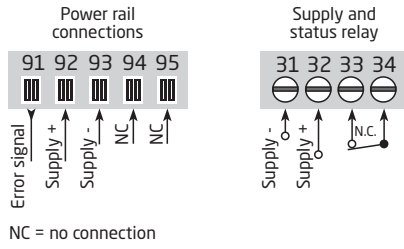

Inputs - 9203xxx:

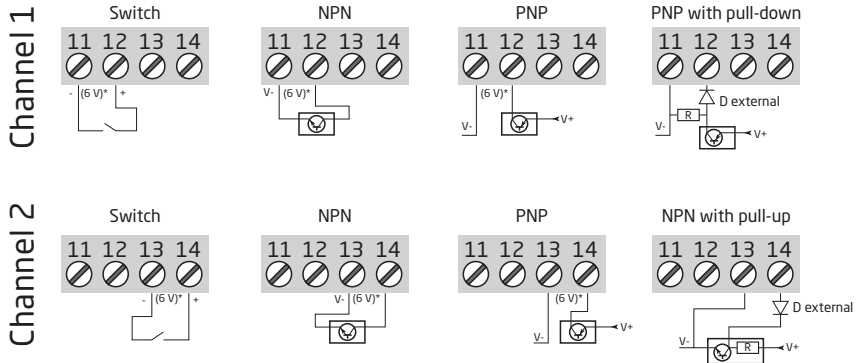

Inputs - 9203xxx1:

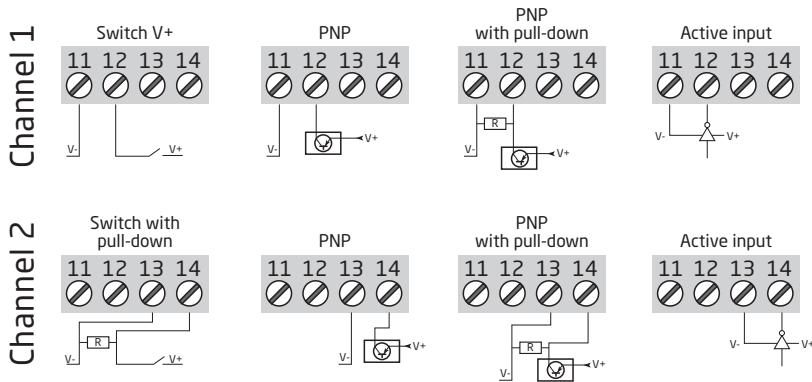

Inputs - 9203xxx2:

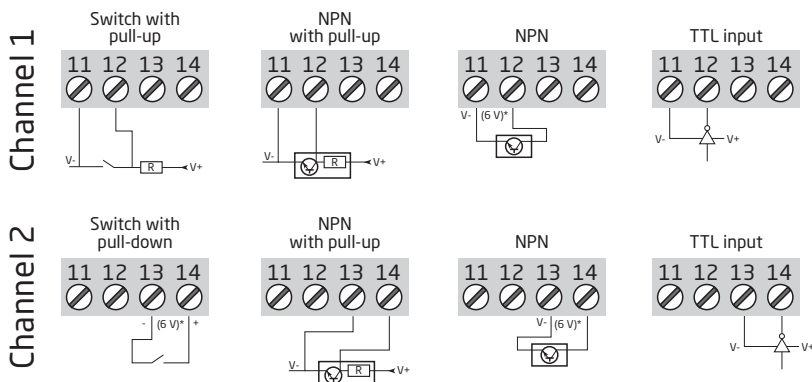

* 6 V at open state

Outputs - 9203xxxx:

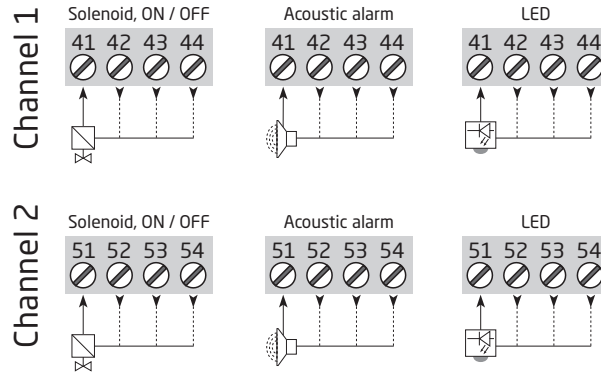

Block diagram

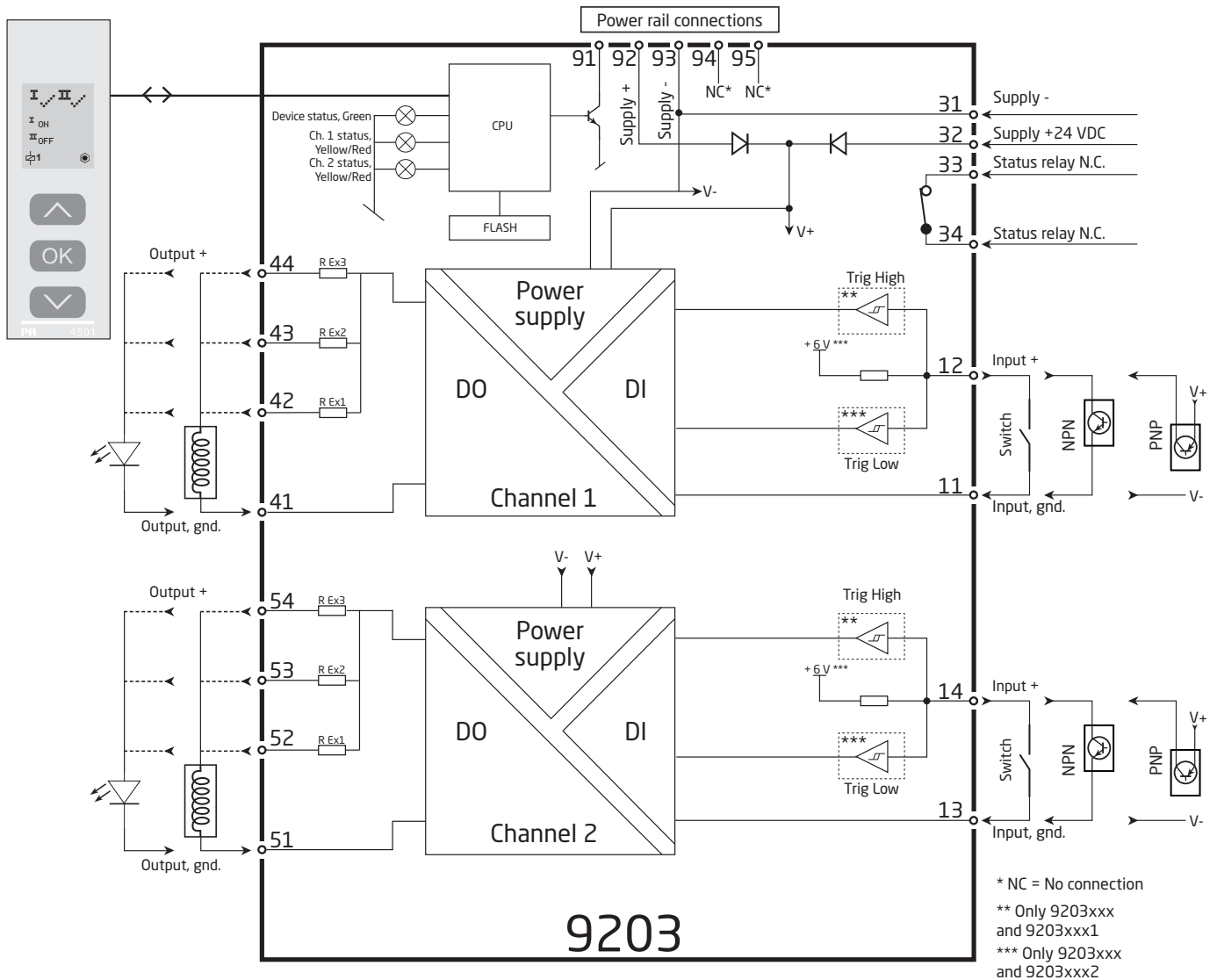

Signal error indications without display front

List of LED and error signal indications					
Condition	Green LED	Ch. 1: Yellow / Red	Ch. 2: Yellow / Red	Status relay, N.C.	Power rail signal status
Device OK	Flashing			Energized	OFF
No supply	OFF	OFF	OFF	De-energized	ON
Device defective	OFF	Red	Red	De-energized	ON
Ch. 1, output ON	Flashing	Yellow		Energized	OFF
Ch. 1, output OFF	Flashing	OFF		Energized	OFF
Ch. 2, output ON	Flashing		Yellow	Energized	OFF
Ch. 2, output OFF	Flashing		OFF	Energized	OFF

Configuration / operating the function keys

Documentation for routing diagram.

In general

When configuring the 9203, you will be guided through all parameters and you can choose the settings which fit the application. For each menu there is a scrolling help text which is automatically shown in line 3 on the display.

Configuration is carried out by use of the 3 function keys:

- ⏪ will increase the numerical value or choose the next parameter
- ⏩ will decrease the numerical value or choose the previous parameter
- ⏹ will save the chosen value and proceed to the next menu

When configuration is completed, the display will return to the default state 1.0. Pressing and holding ⏹ will return to the previous menu or return to the default state (1.0) without saving the changed values or parameters.

If no key is activated for 1 minute, the display will return to the default state (1.0) without saving the changed values or parameters.

Further explanations

Password protection: Programming access can be blocked by assigning a password. The password is saved in the device in order to ensure a high degree of protection against unauthorised modifications to the configuration. Default password 2008 allows access to all configuration menus.

Signal and sensor error indication via display front 4511/4501

The display front can be configured to show output status, output current (load) or tag no. for both channels. When selecting "ALT" the readout toggles between digital output and tag no. In case of hardware error, a help text explaining the error will be displayed.

Advanced functions

The unit gives access to a number of advanced functions which can be reached by answering "Yes" to the point "ADV.SET".

Display setup: Here you can adjust the brightness contrast and the backlight. Setup of TAG numbers with 5 alphanumeric. Selection of functional readout in line 2 and 3 of the display - choose between readout of output status, output current (load) or tag no. When selecting "ALT" the readout toggles between the display options.

Password: Here you can choose a password between 0000 and 9999 in order to protect the unit against unauthorised modifications to the configuration. The unit is delivered default without password.

Language: In the menu "LANG" you can choose between 7 different language versions of help texts that will appear in the menu. You can choose between UK, DE, FR, IT, ES, SE and DK.

Safety Integrity Level (SIL): See Safety Manual for details.



Routing diagram

If no key is activated for 1 minute, the display will return to the default state 1.0 without saving configuration changes.

- ⬆ Increase value / choose next parameter
- ⬇ Decrease value / choose previous parameter
- ⊗ Save the chosen value and proceed to the next menu
- Hold ⊗ Back to previous menu / return to menu 1.0 without saving.

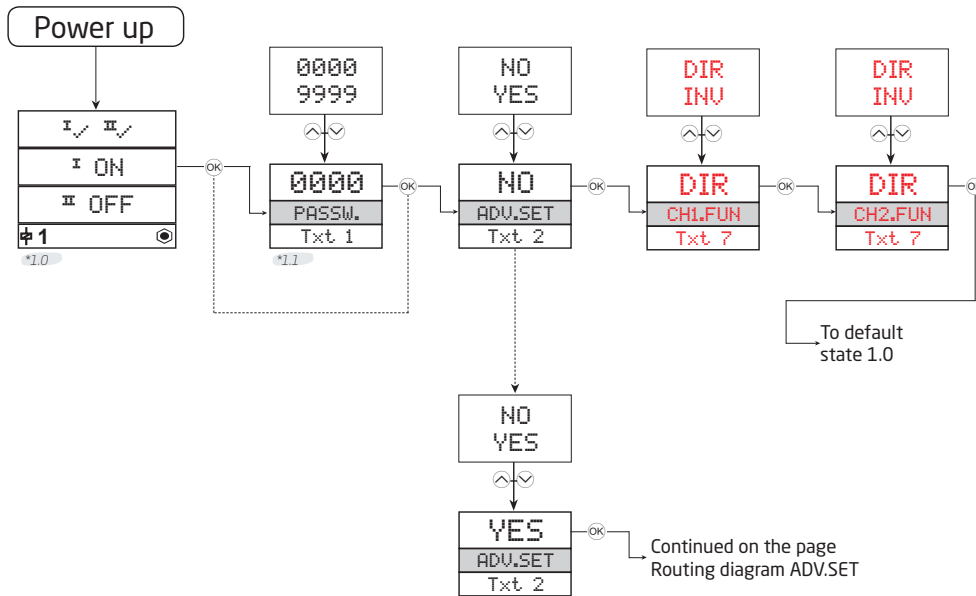

*1.0 Default state.
 Line 1 shows status for channel 1 and channel 2.
 Line 2 shows output status for channel 1, output current or tag no.
 Line 3 shows output status for channel 2, output current or tag no.
 Line 4 indicates whether the device is SIL-locked.

*1.1 Only if password-protected.

Line 1 symbols:
 I/II = OK. Flashing III = error.
 Line 2 and 3 symbols:
 I ON = channel 1 ON
 II OFF = channel 2 OFF
 Line 4 symbols:
 Static dot = SIL-locked
 Flashing dot = Not SIL-locked
 I = output is active

Red text signifies safety parameters in a SIL configuration. See safety manual for details

Routing diagram, advanced settings (ADV.SET)

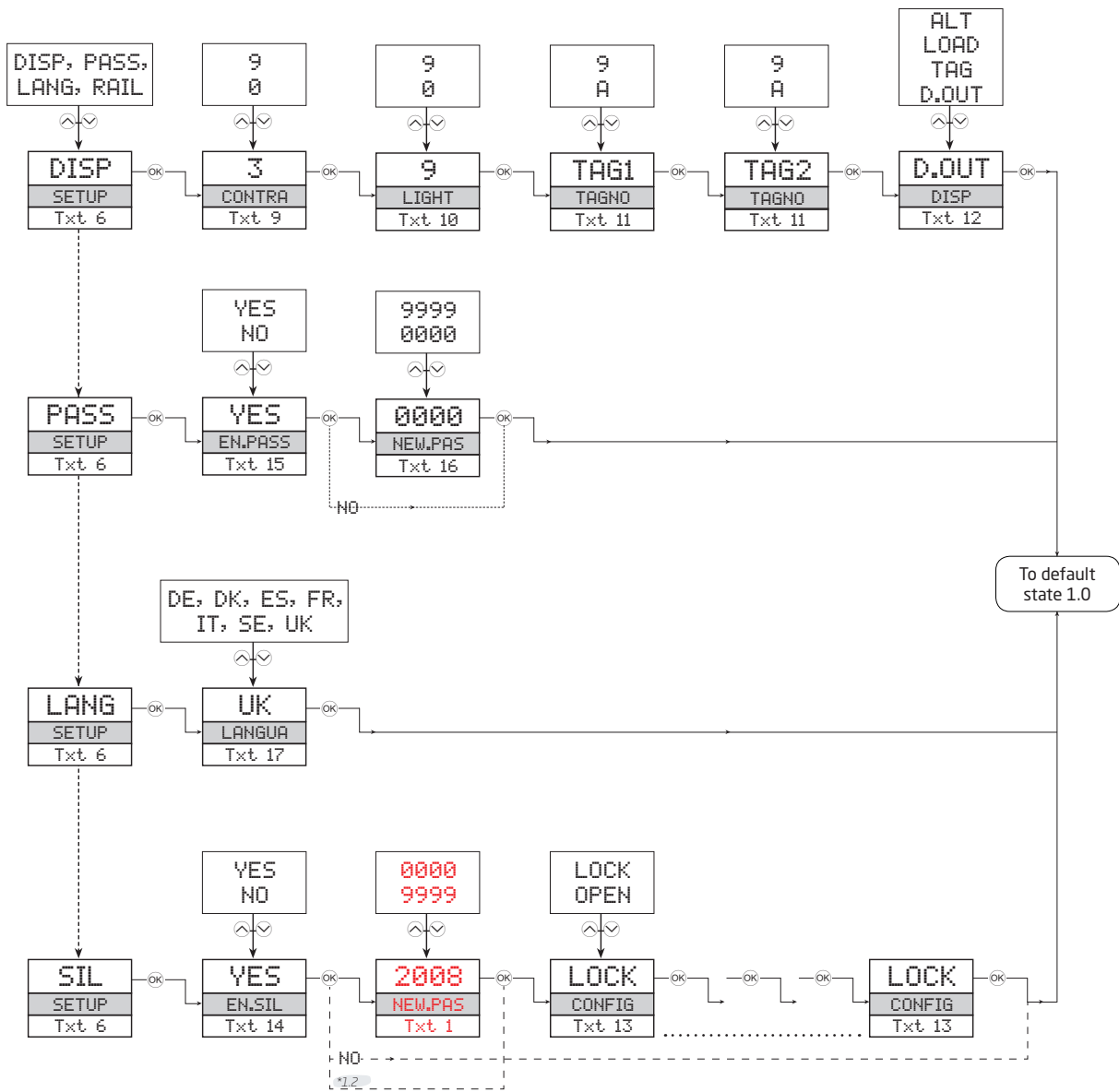

^{1.2} If password has been set.

Help text overview

- [01] Set correct password
- [02] Enter advanced setup?
- [06] Enter language setup
 - Enter password setup
 - Enter display setup
 - Enter SIL setup
- [07] Select direct channel function
 - Select inverted channel function
- [09] Adjust LCD contrast
- [10] Adjust LCD backlight
- [11] Write a 5-character channel tag
- [12] Show output state in display
 - Show output load in display
 - Show tag in display
 - Alternate information shown in display
- [13] Configuration SIL status (Open / Locked)
- [14] Enable SIL configuration lock
- [15] Enable password protection?
- [16] Set new password
- [17] Select language
- [20] No communication - check connections
- [21] EEPROM error - check configuration
- [22] Hardware error

Appendix

IECEX installation drawing

ATEX Installation Drawing

FM Installation Drawing

Desenho de Instalação INMETRO

Safety Manual

LERBAKKEN 10, 8410 RØNDE DENMARK

IECEX Installation drawing



For safe installation of 9203 the following must be observed. The module shall only be installed by qualified personnel who are familiar with the national and international laws, directives and standards that apply to this area.

Year of manufacture can be taken from the first two digits in the serial number.

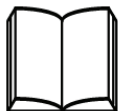

For Installation in Zone 2 / Division 2 the following must be observed.

The 4501 programming module is to be used solely with PRelectronics modules. It is important that the module is undamaged and has not been altered or modified in any way. Only 4501 modules free of dust and moisture shall be installed.

IECEX Certificate: IECEx KEM 09.0001X

Marking 9203Bxxx [Ex ia Ga] IIC/IIB/IIA
Ex nA nC IIC T4 Gc
[Ex ia Da] IIIC
[Ex ia Ma] I

Marking 9203Axxx Ex nA nC IIC T4 Gc

Standards IEC60079-15:2010, IEC60079-11:2011, IEC60079-0:2011

Type	Installation	Current Output	Channels	Input
9203	Non Ex / Zone 2 :A	Low current :1	Single :A	Standard :-
	Ex-Barrier / Zone 2 :B		Double :B	PNP : 1
			High current :2	Single :A

Installation notes.

Install in pollution degree 2, overvoltage category II as defined in IEC60664-1

Do not separate connectors when energized and an explosive gas mixture is present.

Do not mount or remove modules from the Power Rail when an explosive gas mixture is present.

Disconnect power before servicing.

The wiring of unused terminals is not allowed.

In type of protection [Ex ia Da] the parameters for intrinsic safety for gas group IIB are applicable.

For installation in Zone 2, the module shall be installed in an enclosure in type of protection Ex n or Ex e, providing a degree of protection of at least IP54. Cable entry devices and blanking elements shall fulfill the same requirements.

For installation on Power Rail in Zone 2, only Power Rail type 9400 supplied by Power Control Unit type 9410 (IECEX Certificate of Conformity IECEx KEM 08.0025X) is allowed.

LERBAKKEN 10, 8410 RØNDE DENMARK

9203Bxxx Installation:

Hazardous area
Zone 0, 1, 2, 20, 21, 22

Non Hazardous area
or Zone 2

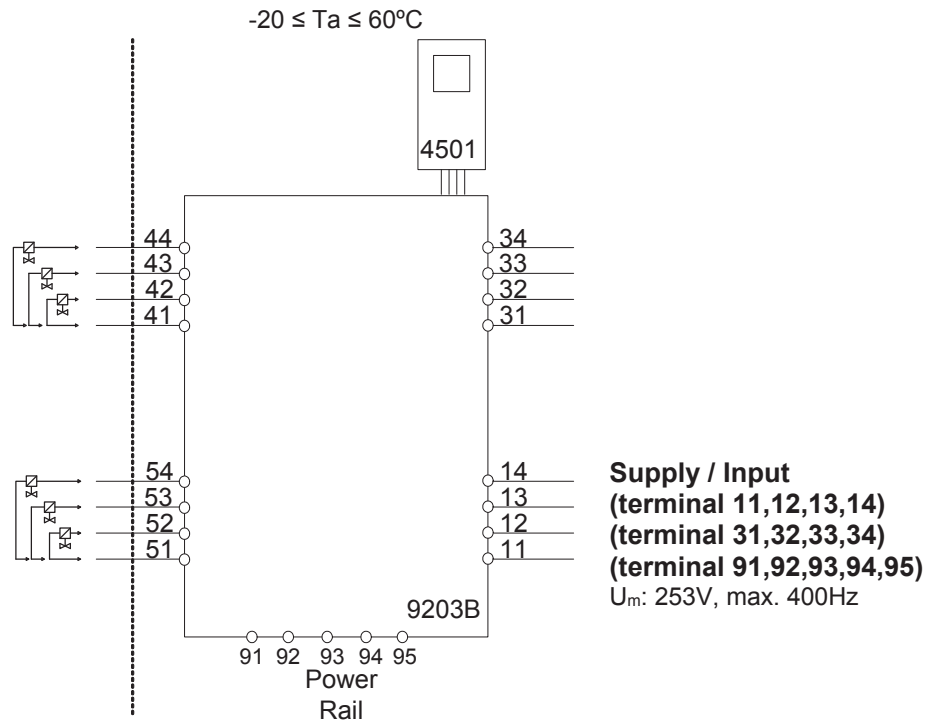

**Terminal (31,32)
Supply:**

Voltage 19.2 – 31.2 VDC
Power max. 3.5 W

**Terminal (11,12 and 13,14)
Input:**

Voltage max 28 VDC
Trig: NPN Low < 2 V, High > 4 V
Trig: PNP Low < 8 V, High > 10 V

Terminal (33,34)

Status Relay: Non Hazardous location
Voltage max. 125 VAC / 110 VDC
Power max. 62.5 VA / 32 W
Current max. 0.5 AAC / 0.3 ADC

Zone 2 installation
32 VAC / 32 VDC
16 VA / 32 W
0.5 AAC / 1 ADC

LERBAKKEN 10, 8410 RØNDE DENMARK

9203B1A, 9203B1B Terminal 41-42/51-52			Co	Lo	Lo/Ro	9203B2A Terminal 41-42			Co	Lo	Lo/Ro
U _o	28V	IIC	80nF	4.2mH	54μH/Ω	U _o	28V	IIC	80nF	2.69mH	44μH/Ω
I _o	93 mA	IIB	640nF	16.8mH	218μH/Ω	I _o	115mA	IIB	640nF	10.8mH	176μH/Ω
P _o	0.65W	IIA	2.1μF	32.6mH	436μH/Ω	P _o	0.81W	IIA	2.1μF	20.8mH	353μH/Ω
		I	3.76μF	32.6mH	436μH/Ω			I	3.76μF	20.8mH	353μH/Ω
9203B1A, 9203B1B Terminal 41-43/51-53			Co	Lo	Lo/Ro	9203B2A Terminal 41-43			Co	Lo	Lo/Ro
U _o	28V	IIC	80nF	3.5mH	54μH/Ω	U _o	28V	IIC			
I _o	100mA	IIB	640nF	14.2mH	218μH/Ω	I _o	125mA	IIB	640nF	9.1mH	163μH/Ω
P _o	0.70W	IIA	2.1μF	27.6mH	436μH/Ω	P _o	0.88W	IIA	2.1μF	17.6mH	327μH/Ω
		I	3.76μF	27.6mH	436μH/Ω			I	3.76μF	17.6mH	327μH/Ω
9203B1A,9203B1B Terminal 41-44/51-54			Co	Lo	Lo/Ro	9203B2A Terminal 41-44			Co	Lo	Lo/Ro
U _o	28V	IIC	80nF	2.9mH	46μH/Ω	U _o	28V	IIC			
I _o	110mA	IIB	640nF	11.8mH	184μH/Ω	I _o	135mA	IIB	640nF	7.8mH	150μH/Ω
P _o	0.77W	IIA	2.1μF	22.8mH	369μH/Ω	P _o	0.95W	IIA	2.1μF	15.1mH	301μH/Ω
		I	3.76μF	22.8mH	369μH/Ω			I	3.76μF	15.1mH	301μH/Ω

LERBAKKEN 10, 8410 RØNDE DENMARK

9203Axxx Installation
Non Classified area or Zone 2

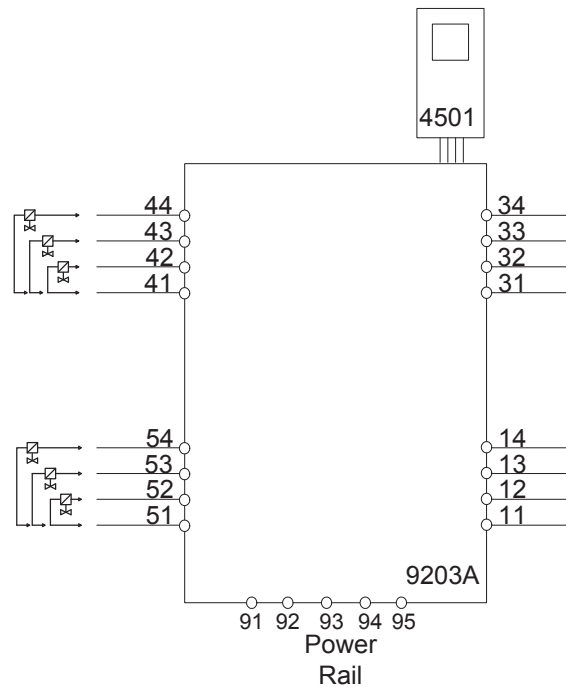

**Terminal (31,32)
Supply:**

Voltage 19.2 – 31.2 VDC
Power max. 3.5 W

**Terminal (11,12 and 13,14)
Input:**

Voltage max 28 VDC
Trig: NPN Low < 2 V, High > 4 V
Trig: PNP Low < 8 V, High > 10 V

Terminal (33,34)

Status Relay: Non Hazardous location
Voltage max. 125 VAC / 110 VDC
Power max. 62.5 VA / 32 W
Current max. 0.5 AAC / 0.3 ADC

Zone 2 installation
32 VAC / 32 VDC
16 VA / 32 W
0.5 AAC / 1 ADC

Terminal (41...44 / 51...54)

Umax 28 V
Imax 135 mA
Pmax 0.95 W

LERBAKKEN 10, 8410 RØNDE DENMARK

ATEX Installation drawing



For safe installation of 9203 the following must be observed. The module shall only be Installed by qualified personnel who are familiar with the national and international laws, directives and standards that apply to this area.

Year of manufacture can be taken from the first two digits in the serial number.



For Installation in Zone 2 / Division 2 the following must be observed.

The 4501 programming module is to be used solely with PRelectronics modules. It is important that the module is undamaged and has not been altered or modified in any way. Only 4501 modules free of dust and moisture shall be installed.

ATEX Certificate KEMA 07ATEX 0147 X

Marking 9203B II (1) G [Ex ia Ga] IIC/IIB/IIA



II 3G Ex nA nC IIC T4 Gc

I (1) D [Ex ia Da] IIIC

I (M1) [Ex ia Ma] I

Marking 9203A II 3G Ex nA nC IIC T4 Gc

Standards EN 60079-0 : 2012, EN 60079-11 : 2012, EN 60079-15 : 2010

Type	Installation	Current Output	Channels	Input
9203	Non Ex / Zone 2 :A	Low current :1	Single :A	Standard :-
			Double :B	PNP : 1
	Ex-Barrier / Zone 2 :B	High current :2	Single :A	NPN : 2

Installation notes.

Install in pollution degree 2, overvoltage category II as defined in EN60664-1

Do not separate connectors when energized and an explosive gas mixture is present.

Do not mount or remove modules from the Power Rail when an explosive gas mixture is present.

Disconnect power before servicing.

The wiring of unused terminals is not allowed.

In type of protection [Ex ia Da] the parameters for intrinsic safety for gas group IIB are applicable.

For installation in Zone 2, the module shall be installed in an enclosure in type of protection Ex n or Ex e, providing a degree of protection of at least IP54. Cable entry devices and blanking elements shall fulfill the same requirements.

For installation on Power Rail in Zone 2, only Power Rail type 9400 supplied by Power Control Unit type 9410 (Type Examination Certificate KEMA 07ATEX0152 X) is allowed.

Revision date:
2015-01-22

Version Revision
V6 R0

Prepared by:
PB

Page:
1/4

LERBAKKEN 10, 8410 RØNDE DENMARK

9203Bxxx Installation:

Hazardous area
Zone 0,1,2, 20, 21, 22

Non Hazardous Area
or Zone 2

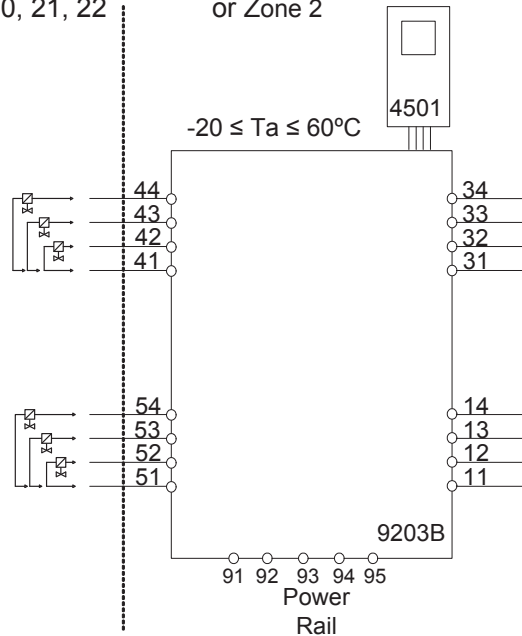

Supply / Input
(terminal 11,12,13,14)
(terminal 31,32,33,34)
(terminal 91,92,93,94,95)
U_m: 253V, max. 400Hz

Terminal (31,32)

Supply:
Voltage 19.2 – 31.2 VDC
Power max. 3.5 W

Terminal (11,12 and 13,14)

Input:
Voltage max 28VDC
Trig: NPN Low < 2V, High > 4V
Trig: PNP Low < 8V, High > 10V

Terminal (33,34)

Status Relay:	Non Hazardous location	Zone 2 installation
Voltage max.	125 VAC / 110 VDC	32 VAC / 32 VDC
Power max.	62.5 VA / 32 W	16 VA / 32 W
Current max.	0.5 AAC / 0.3 ADC	0.5 AAC / 1 ADC

LERBAKKEN 10, 8410 RØNDE DENMARK

9203B1A, 9203B1B Terminal 41-42/51-52			Co	Lo	Lo/Ro	9203B2A Terminal 41-42			Co	Lo	Lo/Ro
U _o	28V	IIC	80nF	4.2mH	54μH/Ω	U _o	28V	IIC	80nF	2.69mH	44μH/Ω
I _o	93 mA	IIB	640nF	16.8mH	218μH/Ω	I _o	115mA	IIB	640nF	10.8mH	176μH/Ω
P _o	0.65W	IIA	2.1μF	32.6mH	436μH/Ω	P _o	0.81W	IIA	2.1μF	20.8mH	353μH/Ω
		I	3.76μF	32.6mH	436μH/Ω			I	3.76μF	20.8mH	353μH/Ω
9203B1A, 9203B1B Terminal 41-43/51-53			Co	Lo	Lo/Ro	9203B2A Terminal 41-43			Co	Lo	Lo/Ro
U _o	28V	IIC	80nF	3.5mH	54μH/Ω	U _o	28V	IIC			
I _o	100mA	IIB	640nF	14.2mH	218μH/Ω	I _o	125mA	IIB	640nF	9.1mH	163μH/Ω
P _o	0.70W	IIA	2.1μF	27.6mH	436μH/Ω	P _o	0.88W	IIA	2.1μF	17.6mH	327μH/Ω
		I	3.76μF	27.6mH	436μH/Ω			I	3.76μF	17.6mH	327μH/Ω
9203B1A, 9203B1B Terminal 41-44/51-54			Co	Lo	Lo/Ro	9203B2A Terminal 41-44			Co	Lo	Lo/Ro
U _o	28V	IIC	80nF	2.9mH	46μH/Ω	U _o	28V	IIC			
I _o	110mA	IIB	640nF	11.8mH	184μH/Ω	I _o	135mA	IIB	640nF	7.8mH	150μH/Ω
P _o	0.77W	IIA	2.1μF	22.8mH	369μH/Ω	P _o	0.95W	IIA	2.1μF	15.1mH	301μH/Ω
		I	3.76μF	22.8mH	369μH/Ω			I	3.76μF	15.1mH	301μH/Ω

LERBAKKEN 10, 8410 RØNDE DENMARK

9203Axxx Installation:
Non Classified area or Zone 2

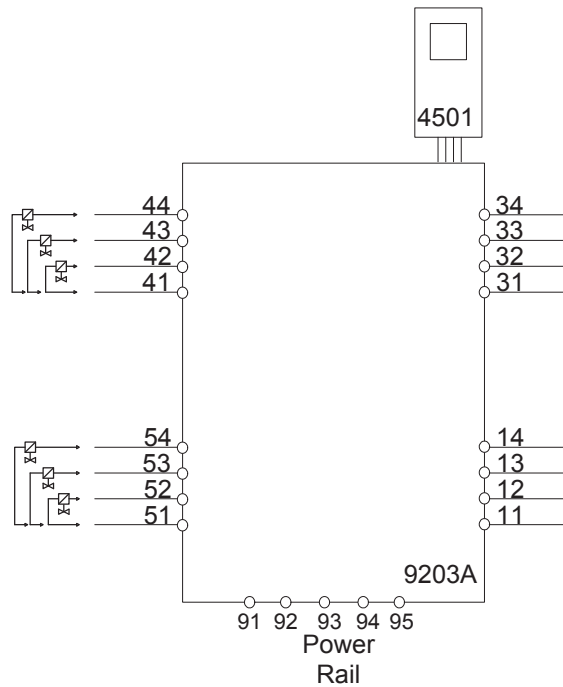

Terminal (31,32)

Supply:

Voltage 19.2 – 31.2 VDC
Power max. 3.5 W

Terminal (11,12 and 13,14)

Input:

Voltage max 28VDC
Trig: NPN Low < 2V, High > 4V
Trig: PNP Low < 8V, High > 10V

Terminal (33,34)

Status Relay:

Voltage max. 125 VAC / 110 VDC
Power max. 62.5 VA / 32 W
Current max. 0.5 AAC / 0.3 ADC

Non Hazardous location

Zone 2 installation

32 VAC / 32 VDC
16 VA / 32 W
0.5 AAC / 1 ADC

Terminal (41..44 / 51..54)

Umax 28 V
Imax 135 mA
Pmax 0.95 W

LERBAKKEN 10, 8410 RØNDE DENMARK

FM Installation drawing



For safe installation of 9203 the following must be observed. The module shall only be installed by qualified personnel who are familiar with the national and international laws, directives and standards that apply to this area.

Year of manufacture can be taken from the first two digits in the serial number.



For Installation in Zone 2 / Division 2 the following must be observed.

The 4501 programming module is to be used solely with PRelectronics modules. It is important that the module is undamaged and has not been altered or modified in any way. Only 4501 modules free of dust and moisture shall be installed.

c-FM-us Certificate 3035277

Type	Installation	Current Output	Channels	Input
9203	Non Ex / Zone 2 :A	Low current :1	Single :A	Standard : -
			Double :B	PNP : 1
	Ex-Barrier / Zone 2 :B	High current :2	Single :A	NPN : 2

Installation notes:

The installation and wiring shall be in accordance with the Canadian Electrical Code for Canada and National Electrical Code NFPA 70, Article 500 or 505 for installation in USA.

The module must be supplied from a Power Supply having double or reinforced insulation.

The use of stranded wires is not permitted for mains wiring except when wires are fitted with cable ends. For installation on the 9400 Power Rail the power must be supplied from Power Control Module Unit 9410.

Install in pollution degree 2, overvoltage category II.

The module must be installed in an enclosure suitable for the environment for which it is used.

For installation in Zone 2 or Division 2, the module must be installed in a suitable outer enclosure according to the regulations in the CEC for Canada or NEC for USA.

The module is galvanically isolated and does not require grounding.

Use 60 / 75 °C copper conductors with wire size AWG: (26-14).

The maximum internal Power dissipation for adjacent modules is assumed to be max. 2W each.

Warning: Substitution of components may impair intrinsic safety and / or suitability for Div. 2 / Zone 2.

Warning: To prevent ignition of explosive atmospheres, disconnect power before servicing and do not separate connectors when energized and an explosive gas mixture is present.

Warning: Do not mount or remove modules from the Power Rail when an explosive gas mixture is present.

Revision date:
2015-01-22

Version Revision
V6R0

Prepared by:
PB

Page:
1/3

LERBAKKEN 10, 8410 RØNDE DENMARK

9203Bxxx Installation:

Hazardous area

Class I/II/III, Division 1, Group A,B,C,D,E,F,G
or Class I, Zone 0/1 Group IIC, [AEx ia] IIC or
or Class I, Zone 0/1 Group IIC, [Ex ia] IIC

Non Hazardous Area or

Class I, Division 2, Group A,B,C,D T4
or Class I, Zone 2 Group IIC T4

Simple Apparatus or
Intrinsically safe apparatus
with entity parameters:

$V_{max}(U_i) \geq V_t(U_o)$
 $I_{max}(I_i) \geq I_t(I_o)$
 $P_i \geq P_t(P_o)$
 $C_a(C_o) \geq C_{cable} + C_i$
 $L_a(L_o) \geq L_{cable} + L_i$

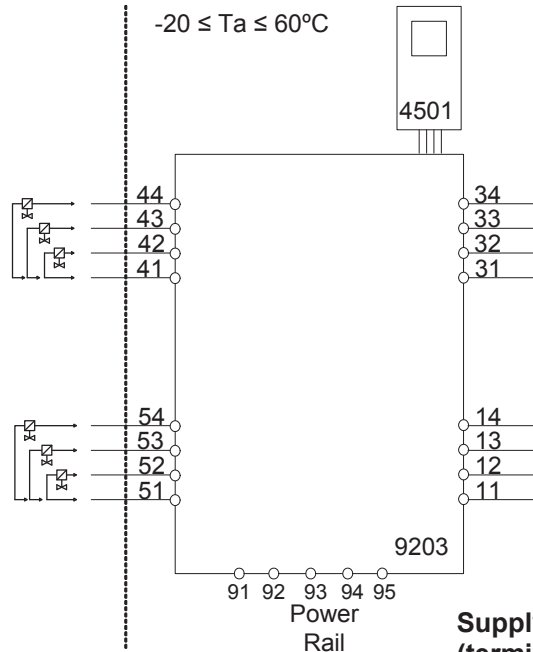

Supply / Input
(terminal 11,12,13,14)
(terminal 31,32,33,34)
(terminal 91,92,93,94,95)
 $U_m: 253V, \text{max. } 400\text{Hz}$

Terminal (31,32)

Supply:

Voltage 19.2 – 31.2 VDC
Power max. 3.5 W

Terminal (11,12 and 13,14)

Input:

Voltage max 28 VDC
Trig: NPN Low < 2 V, High > 4 V
Trig: PNP Low < 8 V, High > 10 V

Terminal (33,34)

Status Relay:

Voltage max. 125 VAC / 110 VDC
Power max. 62.5 VA / 32 W
Current max. 0.5 AAC / 0.3 ADC

Non Hazardous location:

Division 2 or Zone 2 installation:

32 VAC / 32VDC
16 VA / 32 W
0.5 AAC / 1 ADC

LERBAKKEN 10, 8410 RØNDE DENMARK

Module 9203B1A & 9203B1B Terminal 41-42 / 51-52			Co/Ca	Lo/La	Lo/Ro or La/Ra
Uo/Voc	28 V	IIC or A,B	80 nF	4.2 mH	54 μ H/ Ω
Io/Isc	93 mA	IIB or C,E,F	640 nF	16.8 mH	218 μ H/ Ω
Po	0.65 W	IIA or D,G	2.1 μ F	32.6 mH	436 μ H/ Ω

Module 9203B2A Terminal 41-42			Co/Ca	Lo/La	Lo/Ro or La/Ra
Uo/Voc	28 V	IIC or A,B	80 nF	2.69 mH	44 μ H/ Ω
Io/Isc	115 mA	IIB or C,E,F	640 nF	10.8 mH	176 μ H/ Ω
Po	0.81 W	IIA or D,G	2.1 μ F	20.8 mH	353 μ H/ Ω

Module 9203B1A & 9203B1B Terminal 41-43 / 51-53			Co/Ca	Lo/La	Lo/Ro or La/Ra
Uo/Voc	28 V	IIC or A,B	80 nF	3.5 mH	50 μ H/ Ω
Io/Isc	100 mA	IIB or C,E,F	640 nF	14.2 mH	201 μ H/ Ω
Po	0.70 W	IIA or D,G	2.1 μ F	27.6 mH	402 μ H/ Ω

Module 9203B2A Terminal 41-43			Co/Ca	Lo/La	Lo/Ro or La/Ra
Uo/Voc	28 V	IIC or A,B			
Io/Isc	125 mA	IIB or C,E,F	640 nF	9.1 mH	163 μ H/ Ω
Po	0.88 W	IIA or D,G	2.1 μ F	17.6 mH	327 μ H/ Ω

Module 9203B1A & 9203B1B Terminal 41-44 / 51-54			Co/Ca	Lo/La	Lo/Ro or La/Ra
Uo/Voc	28 V	IIC or A,B	80 nF	2.9 mH	46 μ H/ Ω
Io/Isc	110 mA	IIB or C,E,F	640 nF	11.8 mH	184 μ H/ Ω
Po	0.77 W	IIA or D,G	2.1 μ F	22.8 mH	369 μ H/ Ω

Module 9203B2A Terminal 41-44			Co/Ca	Lo/La	Lo/Ro or La/Ra
Uo/Voc	28 V	IIC or A,B			
Io/Isc	135 mA	IIB or C,E,F	640 nF	7.8 mH	150 μ H/ Ω
Po	0.95 W	IIA or D,G	2.1 μ F	15.1 mH	301 μ H/ Ω

9203Axxx Installation:
Non Classified area or Zone 2 or Division 2

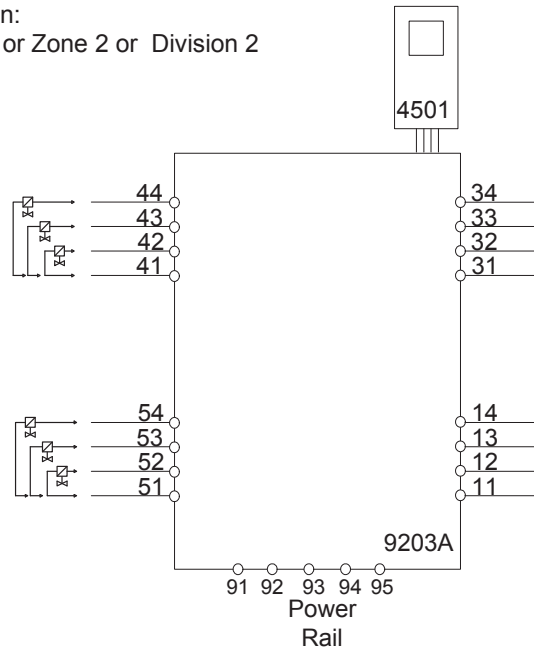

Terminal (31,32)

Supply:

Voltage 19.2 – 31.2 VDC
Power max. 3.5 W

Terminal (11,12 and 13,14)

Input:

Voltage max 28 VDC
Trig: NPN Low < 2 V, High > 4 V
Trig: PNP Low < 8 V, High > 10 V

Terminal (33,34)

Status Relay:

Non Hazardous location
Voltage max. 125 VAC / 110 VDC
Power max. 62.5 VA / 32 W
Current max. 0.5 AAC / 0.3 ADC

Zone 2 installation

32 VAC / 32 VDC
16 VA / 32 W
0.5 AAC / 1 ADC

INMETRO Desenhos para Instalação



Para instalação segura do 9203B o manual seguinte deve ser observado. O módulo deve ser instalado somente por profissionais qualificados que estão familiarizados com as leis nacionais e internacionais, diretrizes e normas que se aplicam a esta área.

Ano de fabricação pode ser obtido a partir dos dois primeiros dígitos do número de série.



4501

Para a instalação na Zona 2 o seguinte deve ser observado. O módulo de programação de 4501, deve ser utilizado apenas com os módulos PRelectronics. É importante que o módulo esteja intacto e não tenha sido alterado ou modificado de qualquer maneira. Apenas os módulos 4501 livres de poeira e umidade devem ser instalados.

INMETRO Certificado **DEKRA 16.0006X**

Marcas 9203Bxxx

[Ex ia Ga] IIC/IIB/IIA
Ex nA nC IIC T4 Gc
[Ex ia Da] IIIC
[Ex ia Ma] I

Normas:

ABNT NBR IEC 60079-0:2013, ABNT NBR IEC60079-11:2013,
ABNT NBR IEC60079-15:2012

Tipo	Instalação	Saída	Canais	Entrada
9203	Barreira Ex / Zona 2 :B	Corrente baixa :1	Simples :A Duplo :B	Estandarte :- PNP : 1
		Corrente alta :2	Simples :A	NPN : 2

Notas de instalação:

Instalação em grau de poluição 2, categoria de sobretensão II conforme definido no IEC 60664-1. Os circuitos não intrinsecamente seguros só pode ser connectado para sobretensão limitado ao categoria I/II como definido na IEC 60664-1

Não separe conectores quando energizado ou quando uma mistura de gás explosivo estiver presente. Não monte ou remova módulos do trilho de alimentação quando uma mistura de gás explosivo estiver presente. Para o grupo I (minas), aplicam-se os parâmetros do grupo IIA.

Desligue a alimentação antes da manutenção. A fiação de terminais sem uso não é permitida.

A fonte de Loop e terminais de entrada de corrente para o mesmo canal não deve ser aplicada ao mesmo tempo.

Em tipo de proteção [Ex ia Da] os parâmetros para a segurança intrínseca para grupo de gás IIB são aplicáveis.

Para a instalação em Zona 2, o módulo deve ser instalado em um invólucro conformidade com o tipo de proteção 'Ex n' ou 'Ex e', fornecendo no mínimo grau de proteção IP54.

Dispositivos de entrada de cabo e elementos de vedação devem cumprir com os mesmos requisitos.

Para a instalação de trilho de energia na Zona 2, apenas o trilho de alimentação Rail 9400 fornecido pela Unidade de Controle de Potência 9410 é permitido.

Área de classificada
Zona 0, 1, 2, 20, 21 e 22

Área de não classificada
ou Zona 2

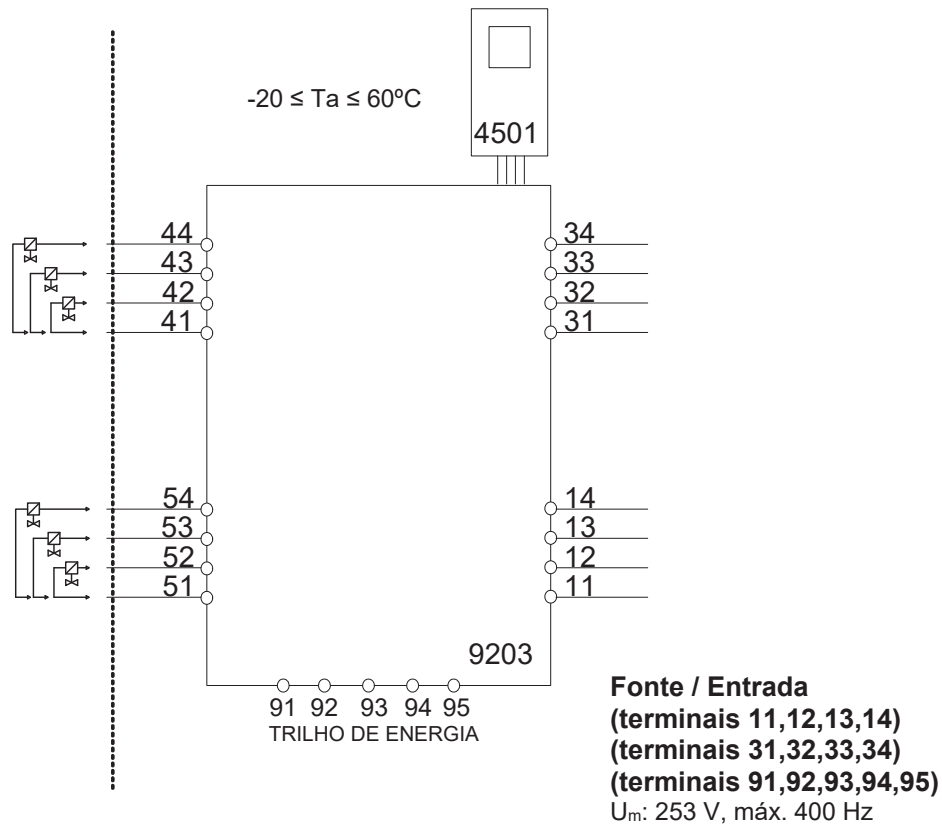

Terminal (31,32)

Fonte:

Voltagem 19,2 – 31,2 VDC
Potência máx. 3,5 W

Terminais (11,12 e 13,14)

Entrada:

Voltagem máx. 28,VDC
Gatilho: NPN Baixo < 2,V, Alto > 4,V
Gatilho: PNP Baixo < 8,V, Alto > 10,V

Terminais (33,34)

Relê de Estado:

Voltagem máx. 125 VAC / 110 VDC
Potência máx. 62,5 VA / 32 W
Corrente máx. 0,5 AAC / 0,3 ADC

Área de não classificada

Instalação Zona 2

32 VAC / 32 VDC
16 VA / 32 W
0,5 AAC / 1 ADC

9203B1A, 9203B1B Terminais 41-42/51-52			Co	Lo	Lo/Ro	9203B2A Terminais 41-42			Co	Lo	Lo/Ro
Uo	28V	IIC	80nF	4.2mH	54μH/Ω	Uo	28V	IIC	80nF	2.69mH	44μH/Ω
Io	93 mA	IIB	640nF	16.8mH	218μH/Ω	Io	115mA	IIB	640nF	10.8mH	176μH/Ω
Po	0.65W	IIA	2.1μF	32.6mH	436μH/Ω	Po	0.81W	IIA	2.1μF	20.8mH	353μH/Ω
9203B1A, 9203B1B Terminais 41-43/51-53			Co	Lo	Lo/Ro	9203B2A Terminais 41-43			Co	Lo	Lo/Ro
Uo	28V	IIC	80nF	3.5mH	50μH/Ω	Uo	28V	IIC			
Io	100mA	IIB	640nF	14.2mH	201μH/Ω	Io	125mA	IIB	640nF	9.1mH	163μH/Ω
Po	0.70W	IIA	2.1μF	27.6mH	402μH/Ω	Po	0.88W	IIA	2.1μF	17.6mH	327μH/Ω
9203B1A,9203B1B Terminais 41-44/51-54			Co	Lo	Lo/Ro	9203B2A Terminais 41-44			Co	Lo	Lo/Ro
Uo	28V	IIC	80nF	2.9mH	46μH/Ω	Uo	28V	IIC			
Io	110mA	IIB	640nF	11.8mH	184μH/Ω	Io	135mA	IIB	640nF	7.8mH	150μH/Ω
Po	0.77W	IIA	2.1μF	22.8mH	369μH/Ω	Po	0.95W	IIA	2.1μF	15.1mH	301μH/Ω

Document history

The following list provides notes concerning revisions of this document.

Rev. ID	Date	Notes
106	1707	Specifications for max. required power added New INMETRO certificate and installation drawing
107	1735	Connection drawings and block diagram updated

SAFETY MANUAL

SOLENOID / ALARM DRIVER

9203

This safety manual is valid for the following product versions:

9203-001

9203-002

9203-003

0. CONTENTS

1. Observed standards	2
2. Acronyms and abbreviations	2
3. Purpose of the product.....	3
4. Assumptions and restrictions for use of the product.....	3
4.1 Basic safety specifications	3
4.2 Associated equipment.....	3
4.2.1 Safety output.....	3
4.2.2 Safety input.....	3
4.3 Failure rates	3
4.4 Safe parameterisation.....	4
4.5 Installation in hazardous areas.....	4
5. Functional specification of the safety functions.....	4
6. Functional specification of the non-safety functions	4
7. Safety parameters	4
8. Hardware and software configuration.....	5
9. Failure category.....	5
10. Periodic proof test procedure	5
11. Procedures to repair or replace the product.....	5
12. Maintenance.....	5
13. Documentation for routing diagram.....	6
13.1 In general.....	6
13.2 Further explanations.....	6
13.2.1 Password protection.....	6
13.4 Advanced functions.....	6
13.4.1 Display setup.....	7
13.4.2 Password.....	7
13.4.3 Language	7
13.4.4 Power rail.....	7
13.4.5 Safety integrity level	7
14 Safe parameterisation - user responsibility	8
14.1 Safety-related configuration parameters.....	8
14.2 Verification procedure	8
14.2.1 If no password is set.....	8
14.2.2 If password is set.....	9
14.3 Functional test.....	9
15. Fault reaction and restart condition.....	9
16 User interface.....	10
16.1 Scrolling help texts in display line 3.....	10
16.3 Routing diagram - Advanced settings (ADV.SET).....	12
17 Connections diagram	13

1. Observed standards

Standard	Description
IEC 61508	Functional Safety of electrical / electronic / programmable electronic safety-related systems
IEC 61508-2:2000	Part 2: Requirements for electrical / electronic / programmable electronic safety-related systems
IEC 61508-3:1998	Part 3: Software requirements
IEC 61326-3-1:2008	Immunity requirements for safety-related systems

2. Acronyms and abbreviations

Acronym / Abbreviation	Designation	Description
Element		Term defined by IEC 61508 as “part of a subsystem comprising a single component or any group of components that performs one or more element safety functions”
PFD	Probability of Failure on Demand	This is the likelihood of dangerous safety function failures occurring on demand.
PFH	Probability of dangerous Failure per Hour	The term “Probability” is misleading, as IEC 61508 defines a Rate.
SFF	Safe Failure Fraction	Safe Failure Fraction summarises the fraction of failures which lead to a safe state and the fraction of failures which will be detected by diagnostic measures and lead to a defined safety action.
SIF	Safety Integrity Function	Function that provides fault detection (to ensure the necessary safety integrity for the safety functions)
SIL	Safety Integrity Level	The international standard IEC 61508 specifies four discrete safety integrity levels (SIL 1 to SIL 4). Each level corresponds to a specific probability range regarding the failure of a safety function.

3. Purpose of the product

The 9203Bxxx can be mounted in the safe area or in zone 2 / div. 2 and transmit signals to zone 0, 1, 2 and zone 20, 21, 22 including M1 mining / Class I/II/III, Div. 1, Gr. A-G. Ex driver for the control of ON / OFF solenoids, acoustic alarms and LEDs mounted in the hazardous area.

The 9203Axxx can be mounted in the safe area or zone 2 / div. 2 and transmit signals to non-hazardous area. Driver for the control of ON / OFF solenoids, acoustic alarms and LEDs mounted in safe area.

The 9203 is controlled by an NPN/PNP signal or a switch signal.

Monitoring of internal error events via the individual status relay and/or a collective electronic signal via the power rail.

The 9203 has been designed, developed and certified for use in SIL 2 applications according to the requirements of IEC 61508.

4. Assumptions and restrictions for use of the product

4.1 Basic safety specifications

Operational temperature range.....	-20...+60°C
Storage temperature range.....	-20...+85°C
Power supply type, min.....	Double or reinforced
Supply voltage	19.2...31.2 VDC
Mounting area	Zone 2 / Division 2 or safe area
Mounting environment	Pollution degree 2 or better

4.2 Associated equipment

4.2.1 Safety output

The safety output shall be connected to the equipment with a minimum load of 10 KΩ

4.2.2 Safety input

The safety input signal frequency shall not be higher than 20 Hz, and the pulse length shall not be shorter than 25 ms.

4.3 Failure rates

The basic failure rates from the Siemens standard SN 29500 are used as the failure rate database.

Failure rates are constant, wear-out mechanisms are not included.

External power supply failure rates are not included.

4.4 Safe parameterisation

The user is responsible for verifying the correctness of the configuration parameters. (See section 14 Safe parameterisation - user responsibility). Manual override may not be used for safety applications.

4.5 Installation in hazardous areas

The IECex Installation drawing, ATEX Installation drawing, INMETRO Installation drawing and FM Installation drawing shall be followed if the products are installed in hazardous areas.

5. Functional specification of the safety functions

Driver for the control of ON / OFF solenoids, acoustic alarms and LEDs.

6. Functional specification of the non-safety functions

The status relay (terminal 33 and 34), error signal on power rail (terminal 91) and LED outputs are not suitable for use in any Safety Instrumented Function.

7. Safety parameters

	9203x1xx	9203x2xx
Probability of dangerous Failure per Hour (PFH)	4.30E-08	4.60E-08
	Note ¹	
Probability of failure on demand (PFD) - 1 year proof test interval	2.73E-04	2.92E-04
Proof test interval (10% of loop PFD)	5 years	4 years
Safe Failure Fraction	91%	91%
Demand response time	<10 ms	
Demand mode	High	
Demand rate	1000 s	
Mean Time To Repair (MTTR)	24 hours	
Diagnostic test interval	10 seconds	
Hardware Fault Tolerance (HFT)	0	
Component Type	B	
SIL capability	SIL 2	
Description of the "Safe State"	De-energised	

Note¹: The 9203 contains no lifetime limiting components, therefore the PFH figures are valid for up to 12 years, according to IEC 61508.

8. Hardware and software configuration

All configurations of software and hardware versions are fixed from factory, and cannot be changed by end-user or reseller.

This manual only covers products labelled with the product version (or range of versions) specified on the front page.

9. Failure category

Failure category	Failure rates (1/h)	
	9203x1xx	9203x2xx
Fail Safe Detected	0.00E+00	0.00E+00
Fail Safe Undetected	4.77E-07	4.80E-07
Fail Dangerous Detected	0.00E+00	0.00E+00
Fail Dangerous Undetected	4.30E-08	4.60E-08

10. Periodic proof test procedure

Step	Action
1	Bypass the safety PLC or take other appropriate action to avoid a false trip
2	Connect a simulator identical to the input setup
3	Perform an ON / OFF signal for each channel
4	Observe whether the output channel acts as expected
5	Restore the input terminals to full operation
6	Remove the bypass from the safety PLC or otherwise restore normal operation

This test will detect approximately 95% of possible "du" (dangerous undetected) failures in the device. The proof test is equivalent to the functional test.

11. Procedures to repair or replace the product

Any failures that are detected and that compromise functional safety should be reported to the sales department at PR electronics A/S.

Repair of the device and replacement of circuit breakers must be done by PR electronics A/S only.

12. Maintenance

No maintenance required.

13. Documentation for routing diagram

The routing diagram is shown in section 16.2.

13.1 In general

When configuring the 9203, you will be guided through all parameters and you can choose the settings which fit the application. For each menu there is a scrolling help text which is automatically shown in line 3 on the display.

Configuration is carried out by use of the 3 function keys:

- ⬆ will increase the numerical value or choose the next parameter
- ⬇ will decrease the numerical value or choose the previous parameter
- Ⓞ will accept the chosen value and proceed to the next menu

When configuration is completed, the display will return to the default state 1.0.

Pressing and holding Ⓞ will return to the previous menu or return to the default state (1.0) without saving the changed values or parameters.

If no key is activated for 1 minute, the display will return to the default state (1.0) without saving the changed values or parameters.

13.2 Further explanations

13.2.1 Password protection

Access to the configuration can be blocked by assigning a password. The password is saved in the device in order to ensure a high degree of protection against unauthorised modifications to the configuration. Default password 2008 allows access to all configuration menus.

Password protection is mandatory in SIL applications.

13.4 Advanced functions

The unit gives access to a number of advanced functions which can be reached by answering "Yes" to the point "adv.set".

13.4.1 Display setup

Here you can adjust the brightness contrast and the backlight. Setup of tag numbers with 5 alphanumerics. Selection of functional readout in line 2 and 3 of the display - choose between readout of digital output or tag no. When selecting "ALT" the readout toggles between digital output and tag no.

13.4.2 Password

Here you can choose a password between 0000 and 9999 in order to protect the device against unauthorised modifications to the configuration. The device is delivered default without password.

13.4.3 Language

In the menu "LANG" you can choose between 7 different language versions of help texts that will appear in the menu. You can choose between UK, DE, FR, IT, ES, SE and DK.

13.4.4 Power rail

In the menu "RAIL" you can choose if errors in the device are transmitted to the central surveillance in the PR 9410 power control unit.

13.4.5 Safety integrity level

See Safe parameterisation - user responsibility

14 Safe parameterisation - user responsibility

14.1 Safety-related configuration parameters

Parameters	Value	Description
CH1.FUN	DIR / INV	Direct / inverted channel function
CH2.FUN.	DIR / INV	Direct / inverted channel function
PASSW	0 - 9999	New password

The above safety-related configuration parameters are marked in red text in the routing diagrams and must be verified by the user in a SIL-configuration.

14.2 Verification procedure

The verification is done using the display / programming front PR 4501 by following the procedure described below.

14.2.1 If no password is set

	Action	Display shows
1	Press OK	ADV.SET
2	Set (ADV.SET) to Yes and press OK	DISP SETUP
3	Step down to (SIL SETUP) and press OK	EN.SIL
4	Set (EN SIL) to YES and press OK	NEW.PASS
5	Set password to a number between 0 and 9999 and press OK (At this time the device starts operating in SIL mode with the entered configuration parameters!)	Verify⇒OPEN "briefly" ⇒LOCK*
6	Press OK to confirm verification of the OPEN-LOCK in the display	CH1.FUN
7	Verify Channel 1 function and press OK	CH2:FUN
8	Verify Channel 2 function and press OK	PASSW
9	Verify password and press OK	SIL.OK
10	Verify SIL and press OK	

* Open is shown briefly in the display.

14.2.2 If password is set

	Action	Display shows
1	Press OK	PASSW
2	Enter password and press OK	ADV.SET
3	Set (ADV.SET) to Yes and press OK	DISP SETUP
4	Step down to (SIL SETUP) and press OK	EN.SIL
5	Set (EN SIL) to YES and press OK (At this time the device starts operating in SIL mode with the entered configuration parameters!)	Verify⇒OPEN "briefly" ⇒LOCK*
6	Press OK to confirm verification of the OPEN-LOCK in the display	CH1.FUN
7	Verify Channel 1 function and press OK	CH2:FUN
8	Verify Channel 2 function and press OK	PASSW
9	Verify password and press OK	SIL.OK
10	Verify SIL and press OK	

* Open is shown briefly in the display

14.3 Functional test

The user is responsible for making a functional test after verification of safety parameters. The procedure for periodic proof test described in section 10 shall be used.

15. Fault reaction and restart condition

When the 9203 detects a fault the output will go to Safe State, in which the safety output will go to "de-energised".

For device faults there are 2 ways of bringing the device out of Safe State.

1. Power cycle the device.
2. Bring the device out of SIL mode (choose "NO" in the menu point "EN.SIL"), and set it back to SIL mode again (choose "YES" in the menu point "EN.SIL" and verify the configuration).

16 User interface

16.1 Scrolling help texts in display line 3

- [[01] Set correct password
- [02] Enter advanced setup?
- [06] Enter language setup
Enter password setup
Enter display setup
Enter SIL setup
- [07] Select direct channel function
Select inverted channel function
- [09] Adjust LCD contrast
- [10] Adjust LCD backlight
- [11] Write a 5-character channel tag
- [12] Show output state in display
Show output load in display
Show tag in display
Alternate information shown in display
- [13] Configuration SIL status (Open / Locked)
- [14] Enable SIL configuration lock
- [15] Enable password protection?
- [16] Set new password
- [17] Select language
- [20] No communication - check connections
- [21] EEprom error - check configuration
- [22] Hardware error

ROUTING DIAGRAM

If no key is activated for 1 minute, the display will return to the default state 1.0 without saving configuration changes.

- ⬆ Increase value / choose next parameter
- ⬇ Decrease value / choose previous parameter
- Ⓚ Accept the chosen value and proceed to the next menu
- Hold Ⓚ Back to previous menu / return to menu 1.0 without saving

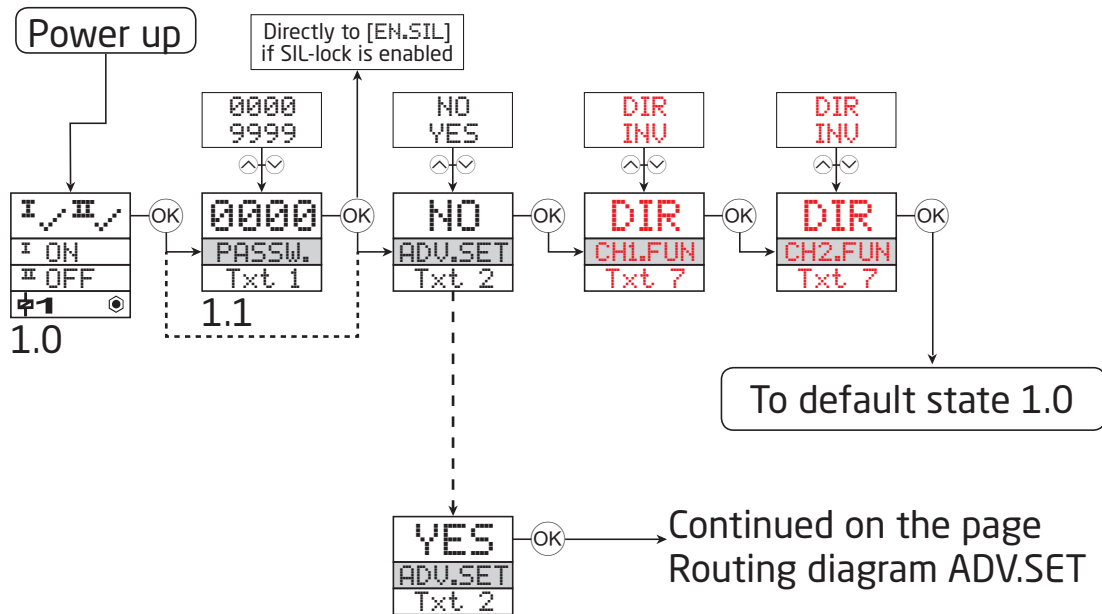

1.0 = Default state
 Line 1 shows status for channel 1 and channel 2.
 Line 2 shows output status for channel 1, output current or tag no.
 Line 3 shows output status for channel 2, output current or tag no.
 Line 4 indicates whether the module is SIL-locked.

1.1 = Only if password-protected.

1.2 If password has been set.

Line 1 symbols:

ⓘ✓ = OK. Flashing ⓘ! = error.

Line 2 and 3 symbols:

ⓘ ON = channel 1 ON

ⓘ OFF = channel 2 OFF.

Line 4 symbols:

Static dot = SIL-locked.

Flashing dot = Not SIL-locked.

Ⓚ = output is active.

16.3 Routing diagram - Advanced settings (ADV.SET)

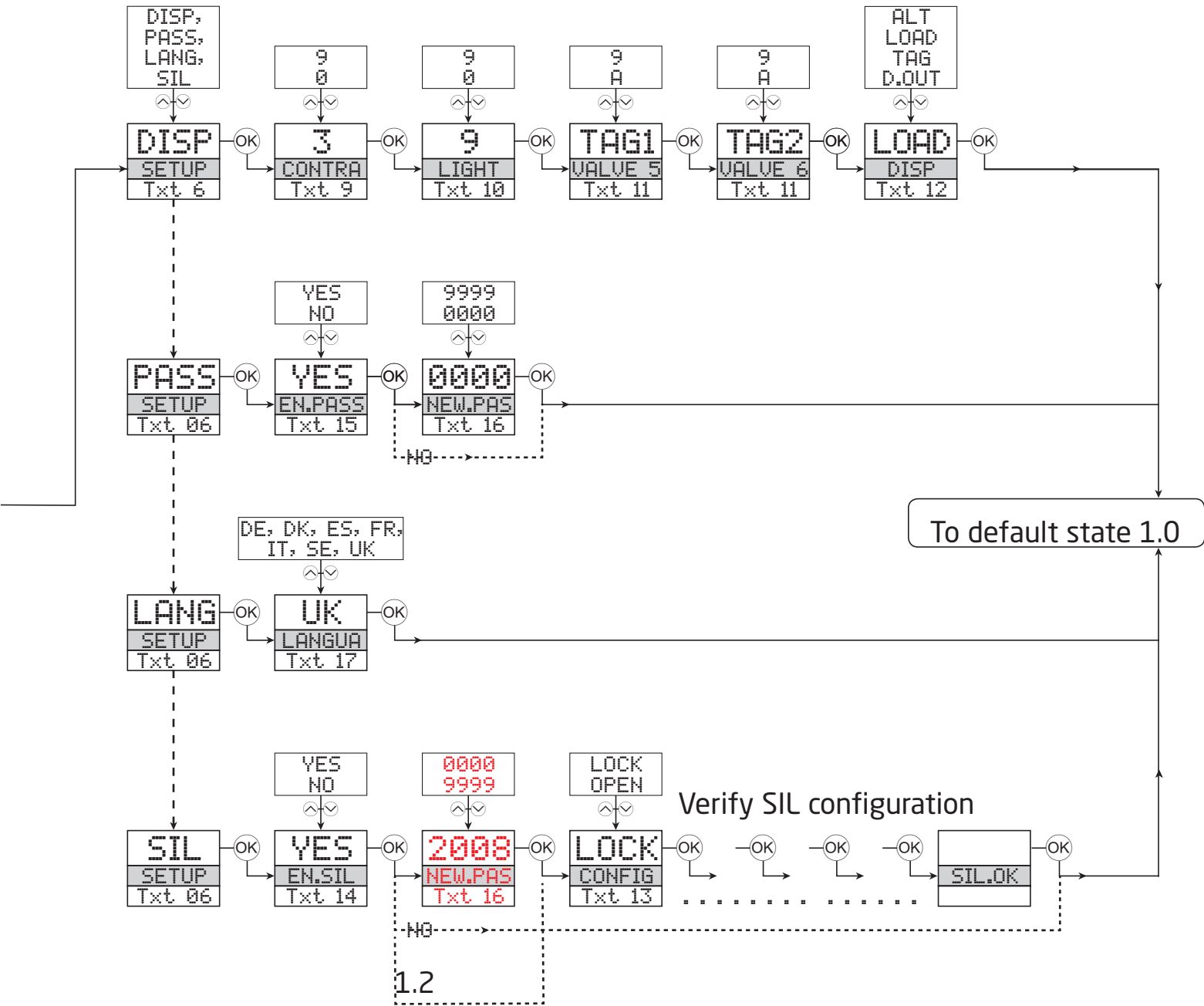

17 Connections diagram

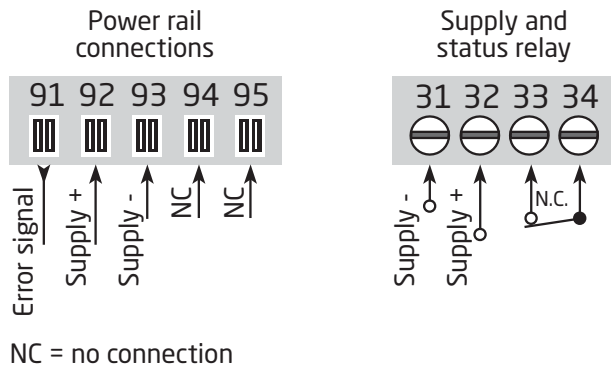

Inputs - 9203xxx:

Channel 1

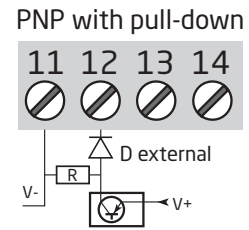
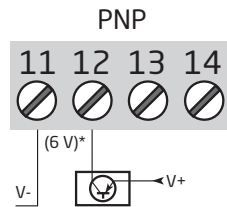
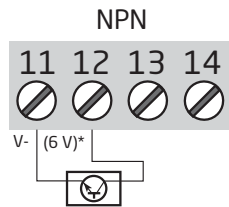
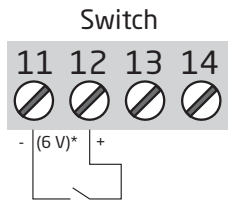

Channel 2

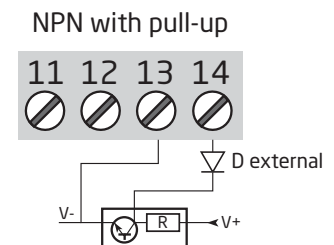
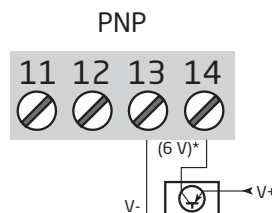
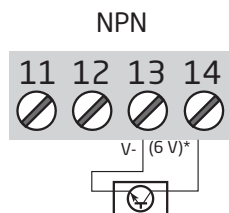
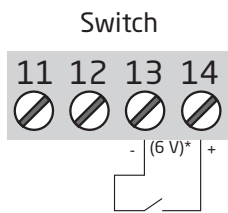

Inputs - 9203xxx1:

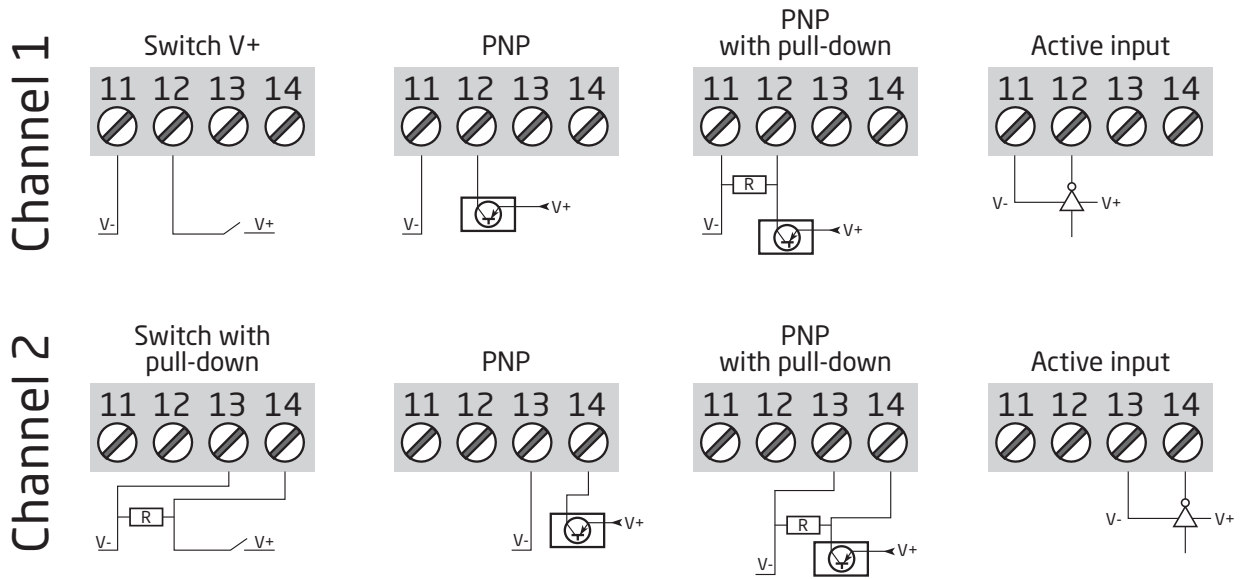

Inputs - 9203xxx2:

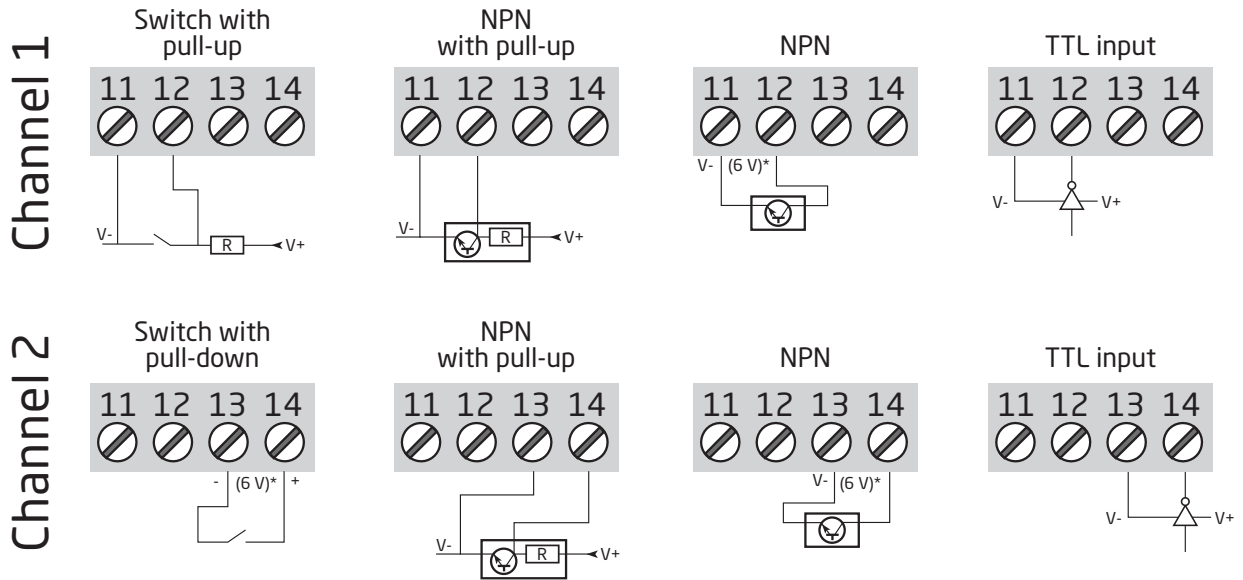

* 6 V at open state

Outputs - 9203xxxx:

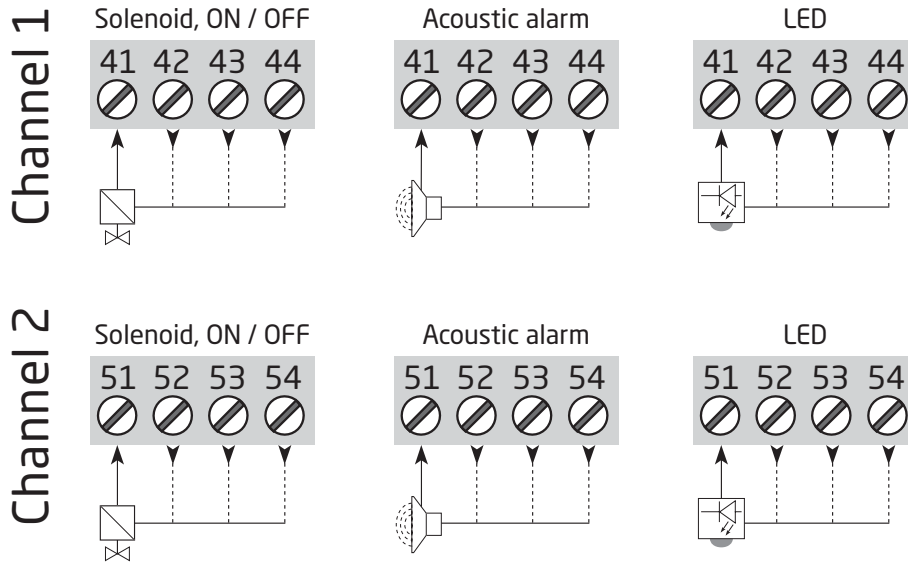

We are near you, *all over the world*

Our trusted red boxes are supported wherever you are

All our devices are backed by expert service and a 5-year warranty. With each product you purchase, you receive personal technical support and guidance, day-to-day delivery, repair without charge within the warranty period and easily accessible documentation.

We are headquartered in Denmark, and have offices and authorized partners the world over. We are a local

business with a global reach. This means that we are always nearby and know your local markets well. We are committed to your satisfaction and provide **PERFORMANCE MADE SMARTER** all around the world.

For more information on our warranty program, or to meet with a sales representative in your region, visit prelectronics.com.

Benefit today from *PERFORMANCE MADE SMARTER*

PR electronics is the leading technology company specialized in making industrial process control safer, more reliable and more efficient. Since 1974, we have been dedicated to perfecting our core competence of innovating high precision technology with low power consumption. This dedication continues to set new standards for products communicating, monitoring and connecting our customers' process measurement points to their process control systems.

Our innovative, patented technologies are derived from our extensive R&D facilities and from having a great understanding of our customers' needs and processes. We are guided by principles of simplicity, focus, courage and excellence, enabling some of the world's greatest companies to achieve PERFORMANCE MADE SMARTER.